

Analysis of aqueous fluids by Raman spectroscopy

Marie-Camille CAUMON





Outline

1. Geological fluids
2. Differential Raman scattering cross sections
3. CO₂ & H₂O
4. Experimental HP-HT devices
5. Some examples



What are geological fluids?



The chemist's fluid:

- Water-based
 - Room temperature
 - Eq. atmospheric gases
 - Low salt concentration
 - Easy to sample
-
- Chemistry of diluted media
 - Classical analytical techniques



What are geological fluids?



The geologist's fluid :

- Large temperature range ($< 0^{\circ}\text{C} \rightarrow > 1000^{\circ}\text{C}$)
 - High pressure (atm. P $\rightarrow > 2$ GPa)
 - Complex chemical systems (large salt concentration, organic species, dissolved gases...)
 - Low water content (silicate fluids)
 - Samples?
- Specific chemistry (Pitzer, etc.)
 - Specific analytical tools

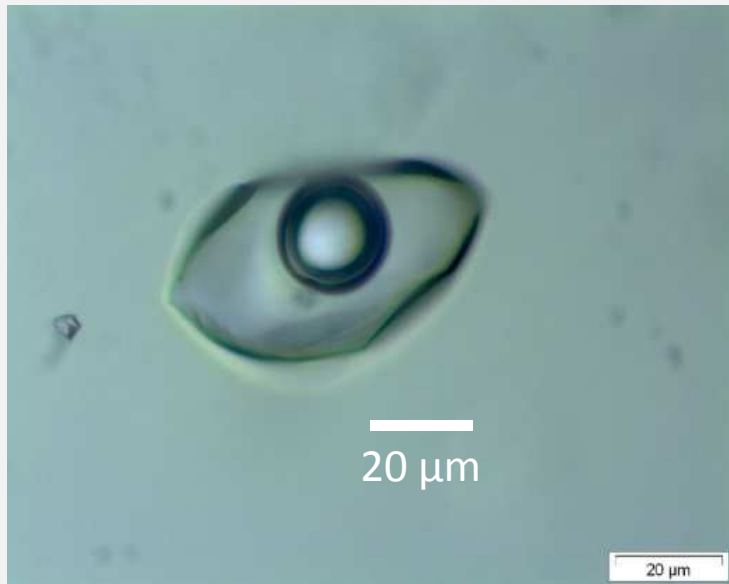

Entrapped in fluid inclusions = μ volumes

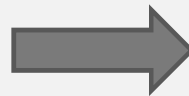

- Raman spectroscopy of geological fluids:
 - Molecular composition = $f(P,T,V)$
 - Water structure
 - Localized: μ volumes
 - Non-destructive
 - \sim Quantitative



Relative differential Raman scattering cross sections



Relative differential Raman scattering cross sections

Gas:

$$\frac{\partial \sigma}{\partial \Omega} = \frac{(2\pi)^4 b_j^2 g_j (45\alpha_j^2 + 7\gamma_j^2) (\nu_0 - \nu_j)^4}{45 \left[1 - \exp\left(-\frac{hc\nu_j}{kT}\right) \right]}$$

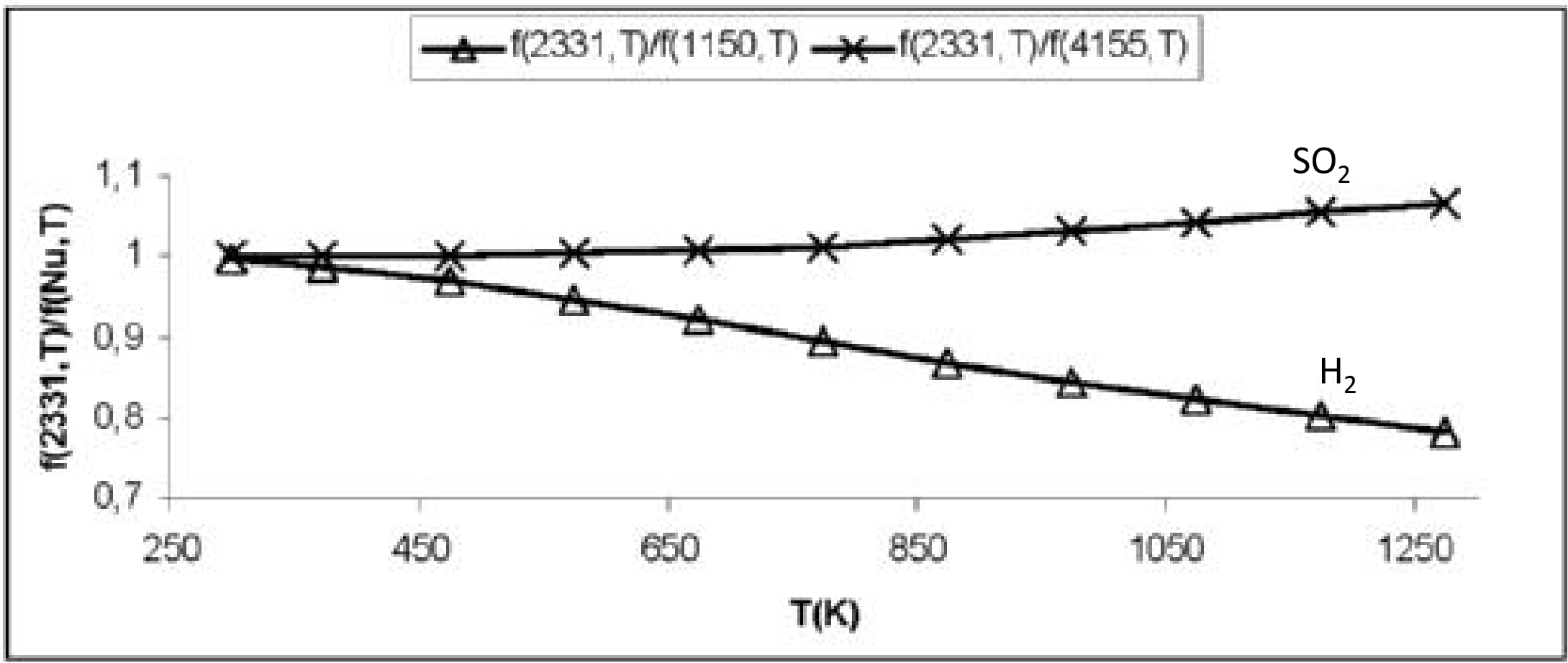
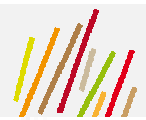

Variation of RDRSCS with T

Garci Baonza *et al.*, EMU Notes vol.12, 2012



Differential Raman scattering cross sections

Gas:
$$\frac{\partial \sigma}{\partial \Omega} = \frac{(2\pi)^4 b_j^2 g_j (45\alpha_j^2 + 7\gamma_j^2) (\nu_0 - \nu_j)^4}{45 \left[1 - \exp\left(-\frac{h\nu_j}{kT}\right) \right]}$$

Schrötter & Klöckner 1979

- For one gas:
$$A_i = I_0 \times C_i \times \frac{\partial \sigma_i}{\partial \Omega} \times t \times \xi_i$$

- For a gas mixture:
$$\frac{C_i}{\sum C_i} = \frac{A_i / \left(\frac{\partial \sigma_i}{\partial \Omega} \times \xi_i \right)}{\sum A_i / \left(\frac{\partial \sigma_i}{\partial \Omega} \times \xi_i \right)} = \frac{A_i / \sigma_i^*}{\sum A_i / \sigma_i^*}$$

Wopenka & Pasteris, Appl. Spectr. 1986

- In liquid:
$$\frac{\partial \sigma}{\partial \Omega} (\text{liquid}) = \frac{\partial \sigma}{\partial \Omega} (\text{gas}) \times L \quad L = \frac{n_j(n_j + 2)^2(n_0 + 2)^2}{81n_0} \approx \frac{(n_0 + 2)^4}{81}$$

L: internal field effect factor

Eckhardt & Wagner, J Mol Spectr 1966



CO₂ and water



The Raman spectrum of CO₂

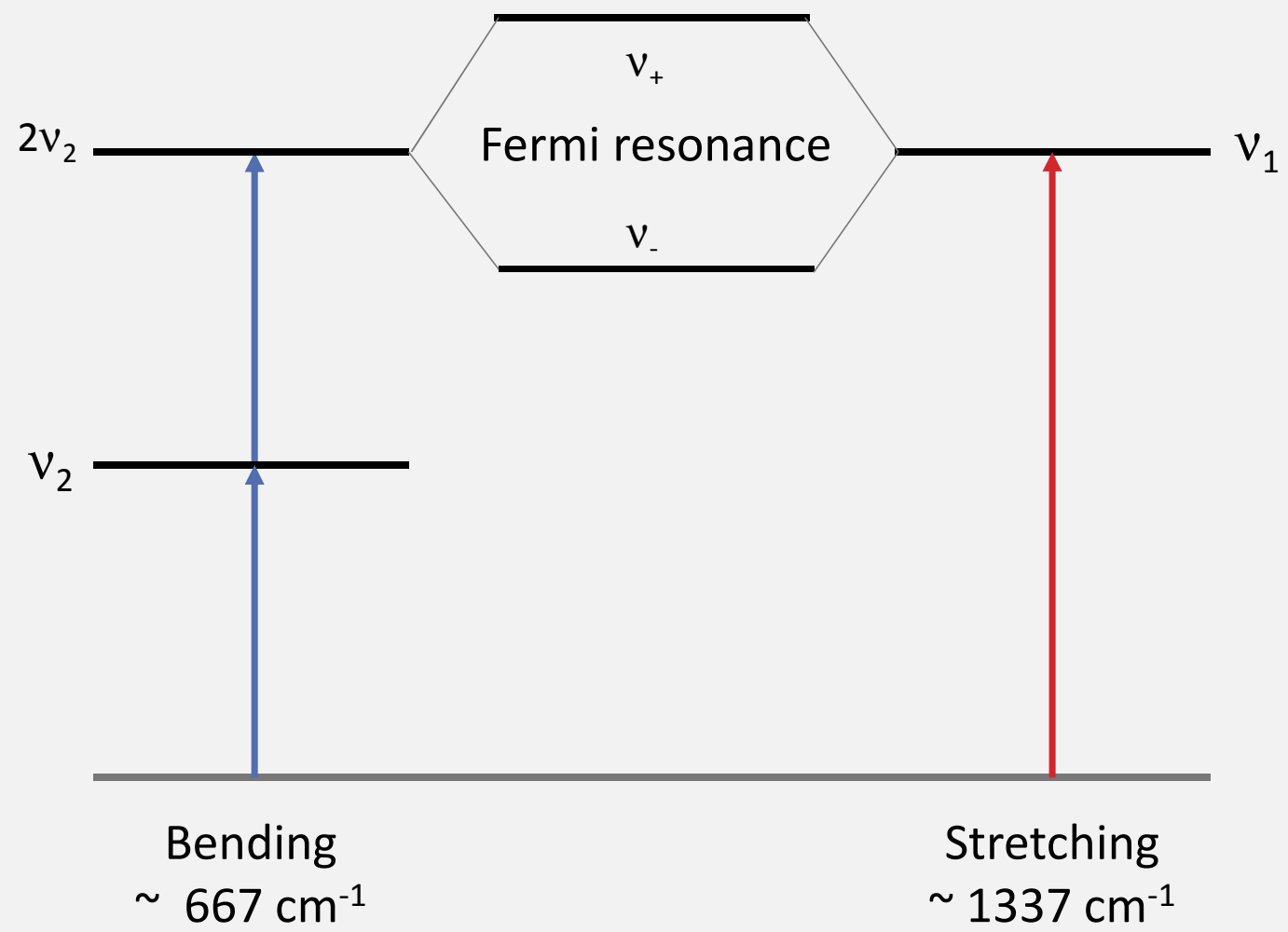

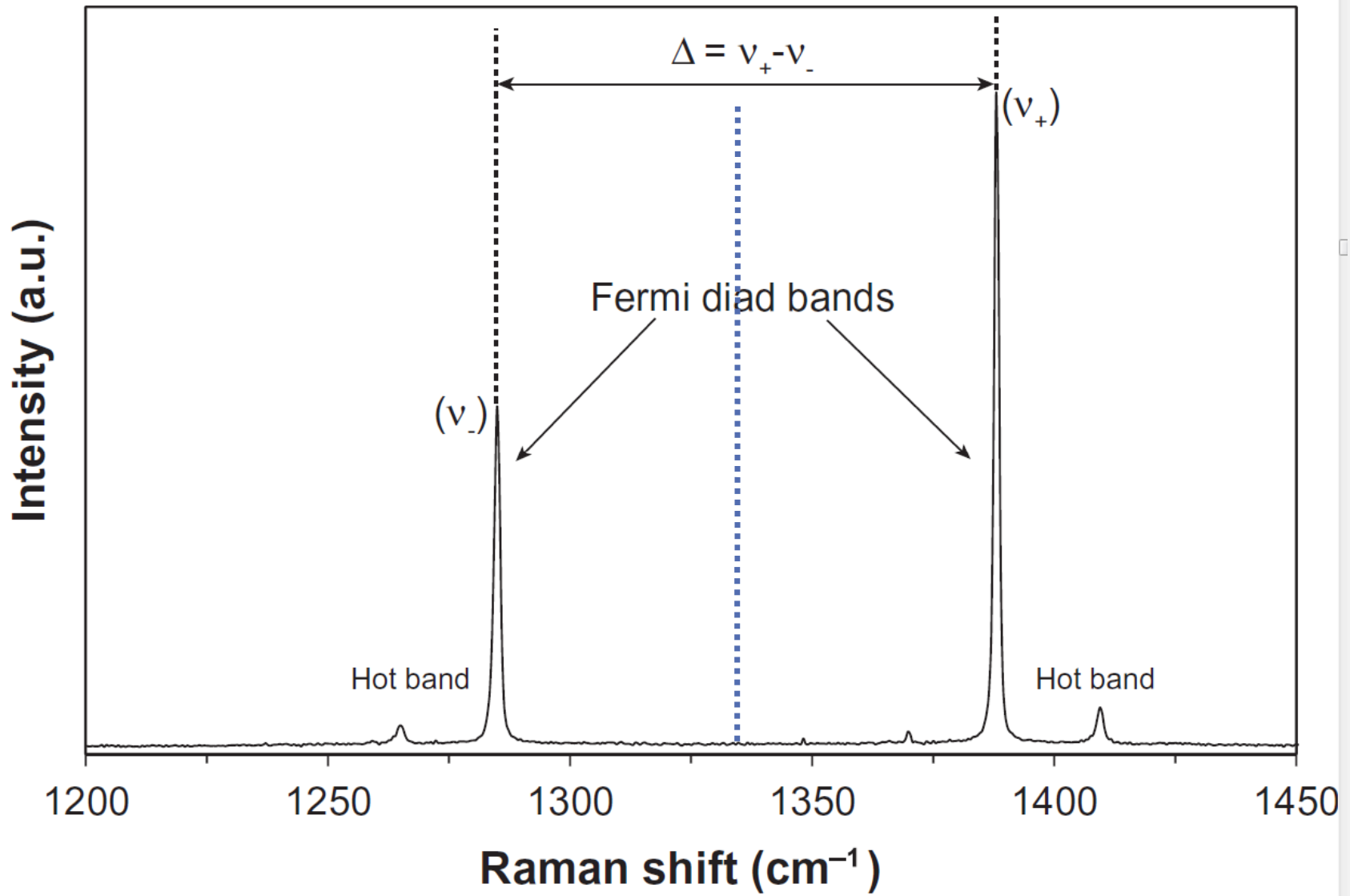

Fall *et al.* GCA 2011

TABLE II. Some CO₂ transitions giving bands in the 4.3- μ region.

Lower state $v_1v_2^lv_3$	Upper state $v_1v_2^lv_3$	Lower-state population	
		300°K	1273°K
00 ⁰ 0	00 ⁰ 1	0.920	0.211
01 ¹ 0	01 ¹ 1	0.074	0.199
02 ² 0	02 ² 1	0.003	0.094
03 ³ 0	03 ³ 1	<0.001	0.044
04 ⁴ 0	04 ⁴ 1	<0.001	0.021
00 ⁰ 1	00 ⁰ 2	<<0.001	0.015
00 ⁰ 2	00 ⁰ 3	<<0.001	0.001

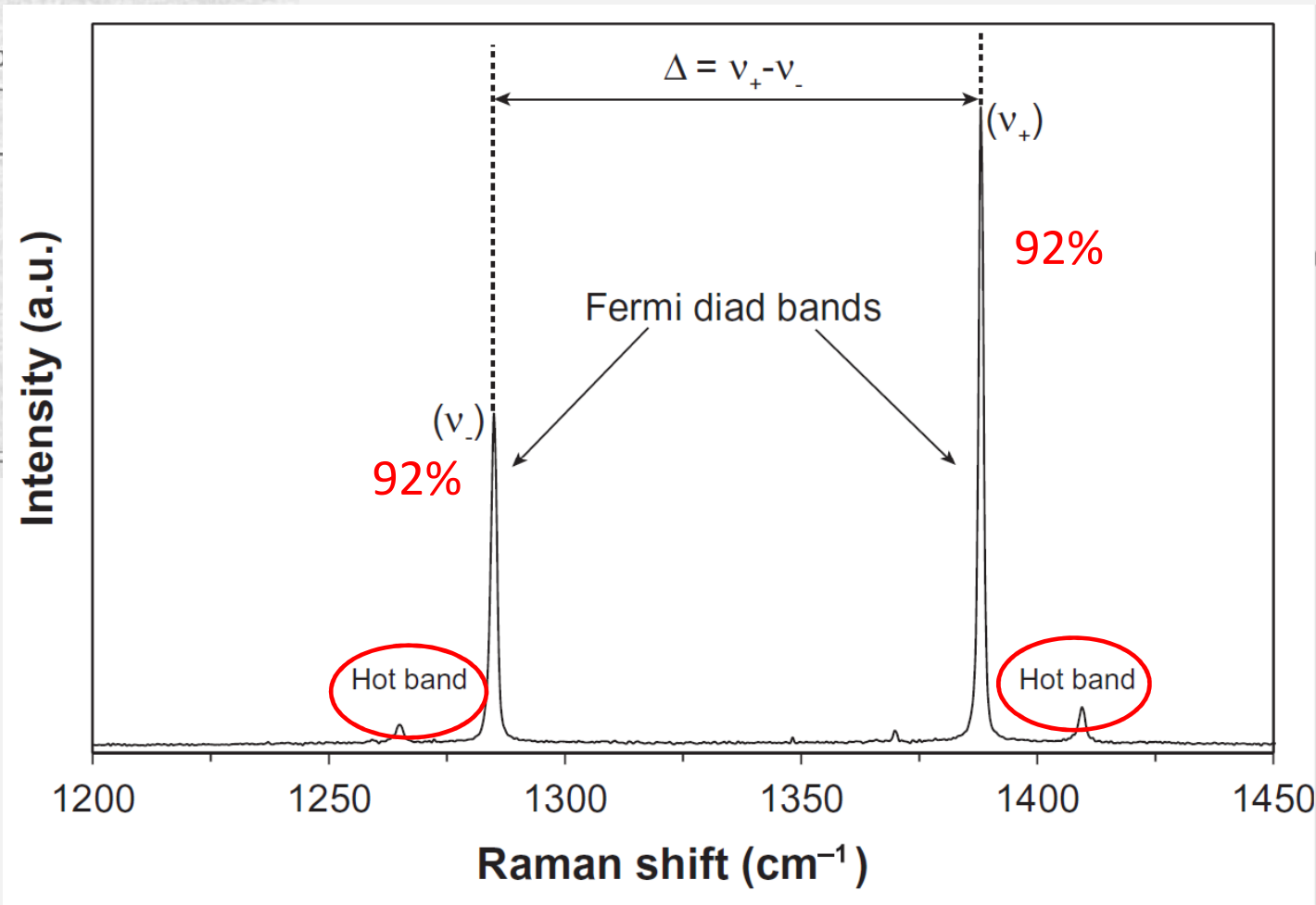

Tourin, JOSA 1961

At room temperature, 92% of CO₂ molecules are in the ground vibrational state.



Density effects on Fermi diad splitting and intensity

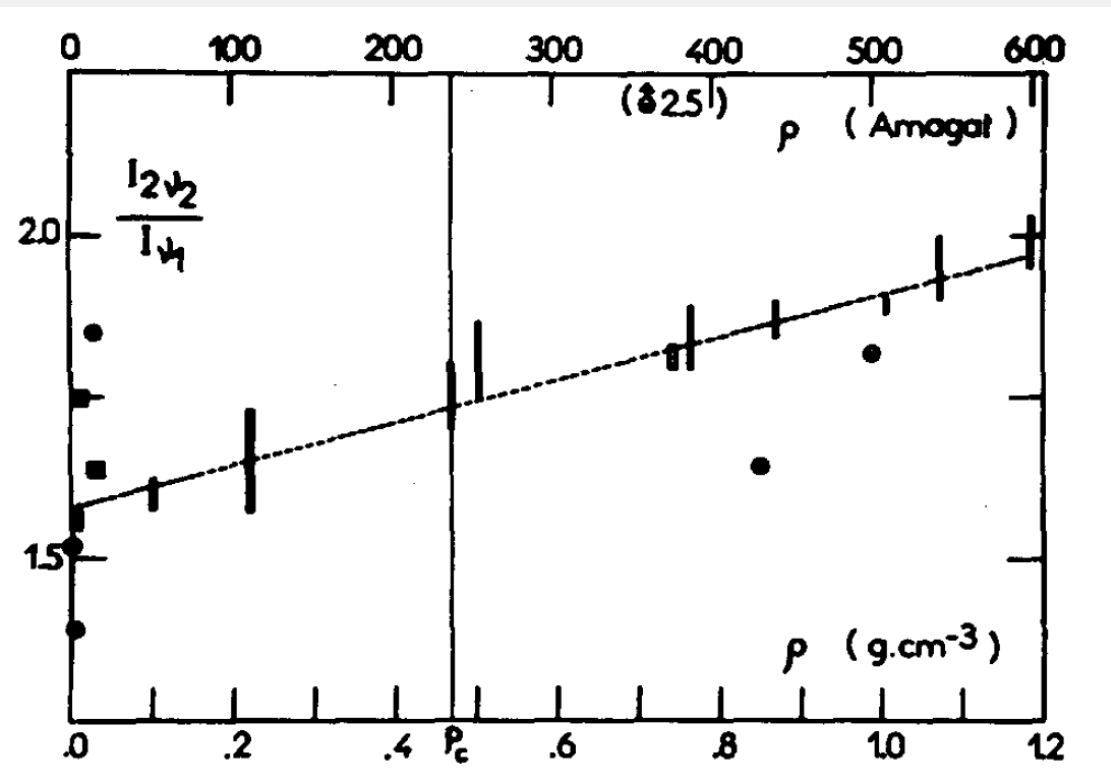

Garrabos *et al.* J Chem Phys, 1980

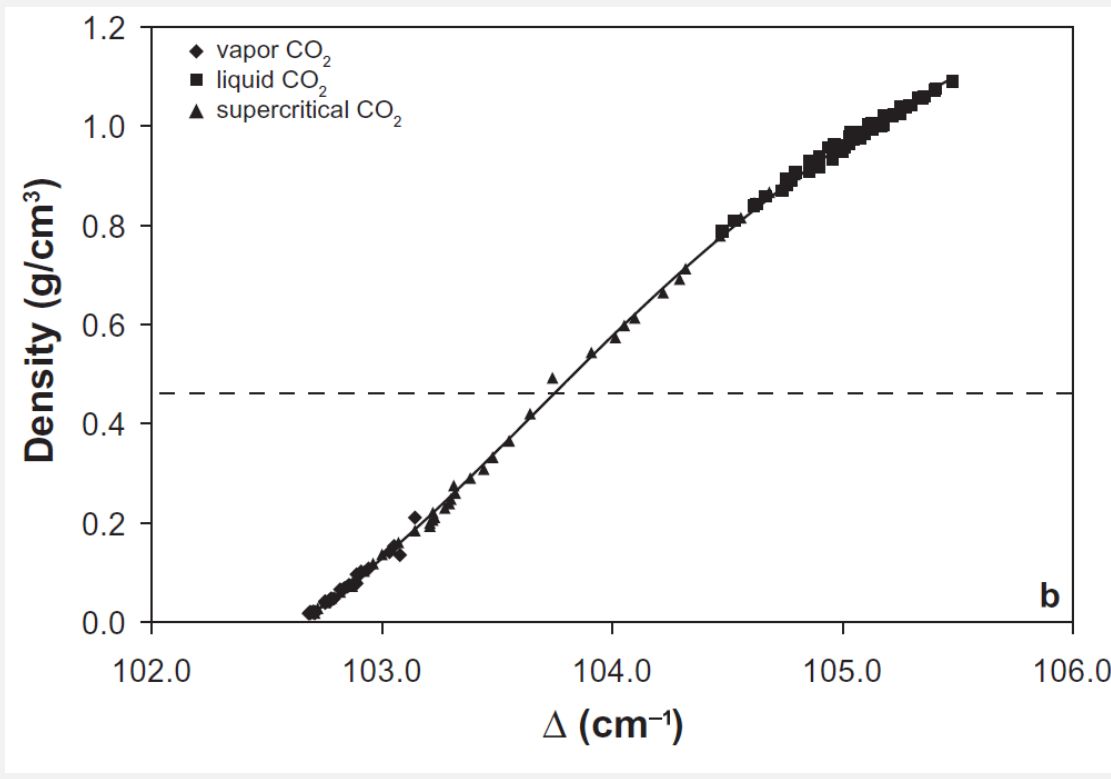

Fall *et al.* GCA 2011

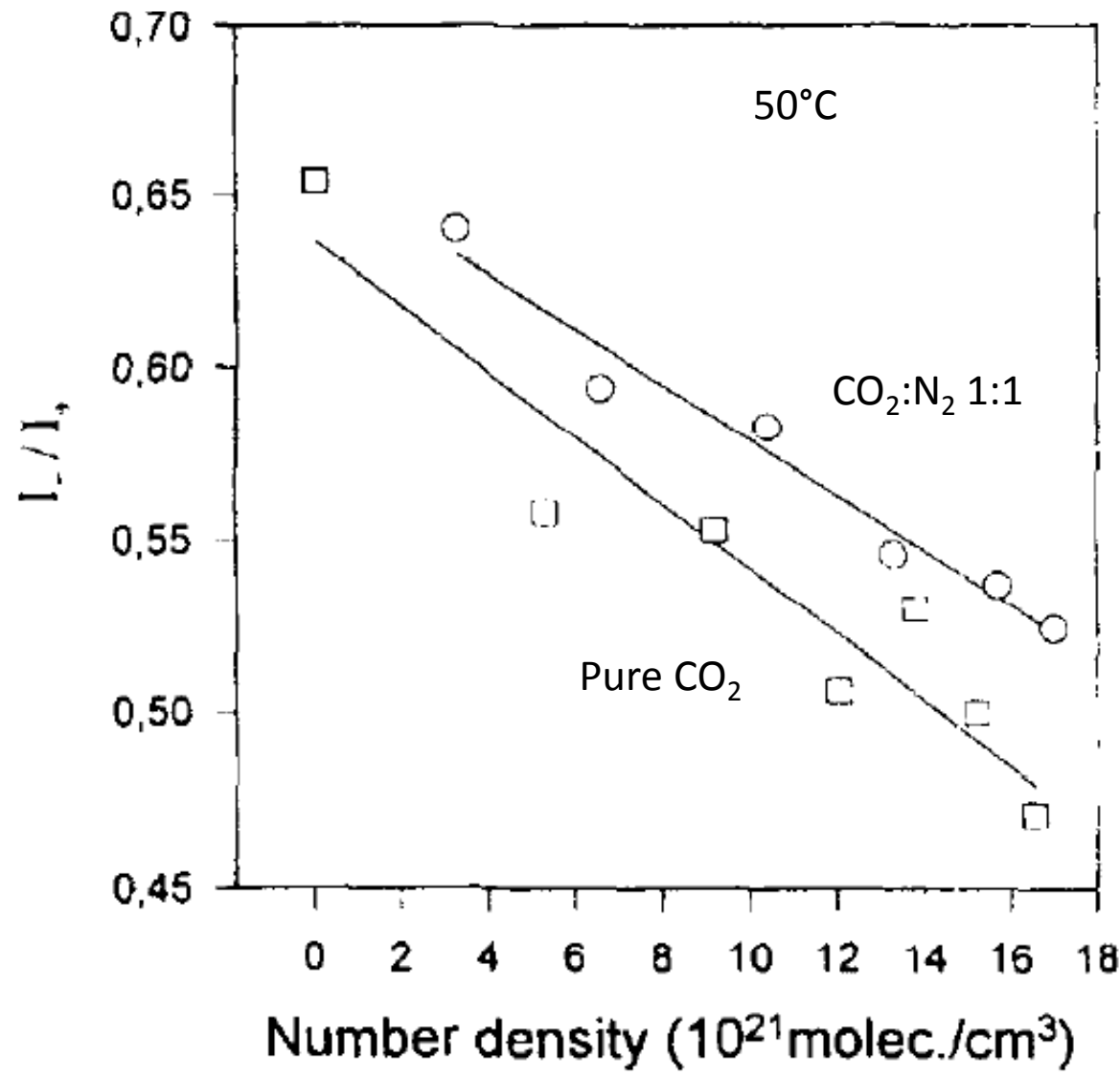

Effect of gas mixture composition



Raman spectroscopy of liquid water and aqueous solutions

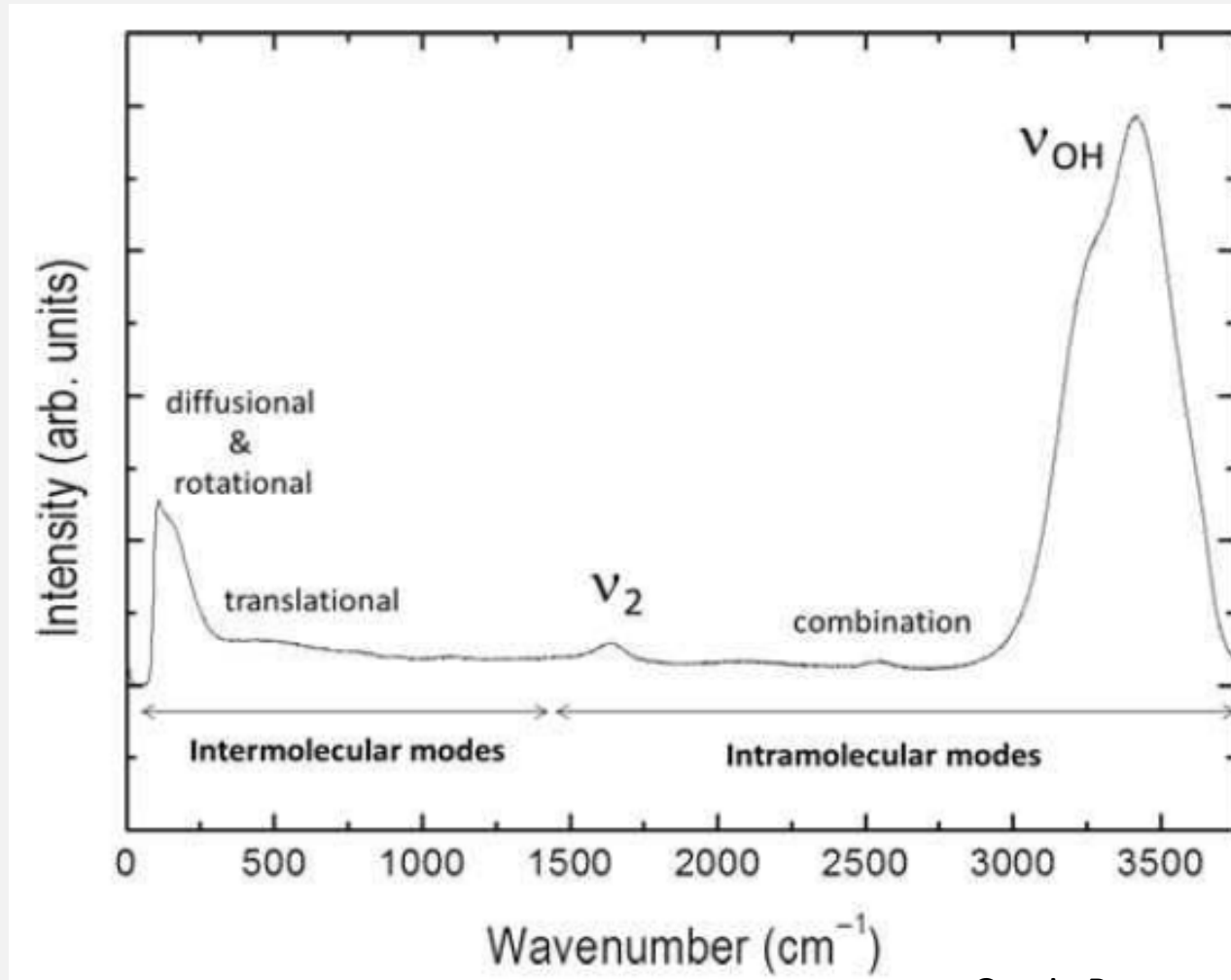

Garcia Baonza *et al.*, *EMU Notes vol.12*, 2012

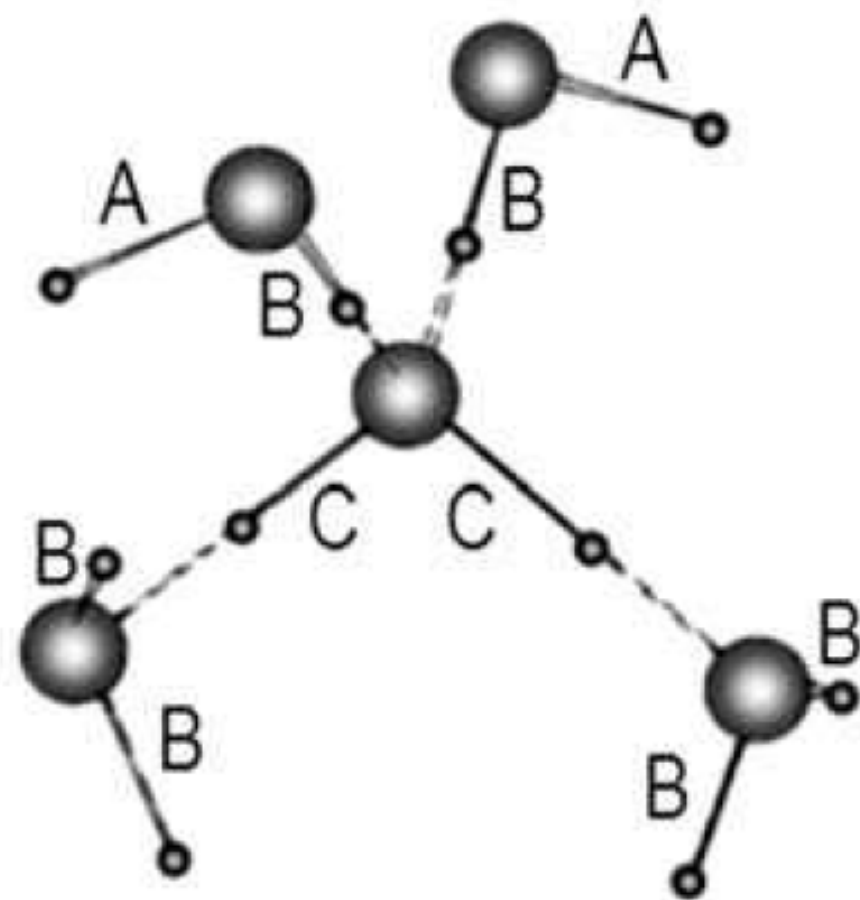
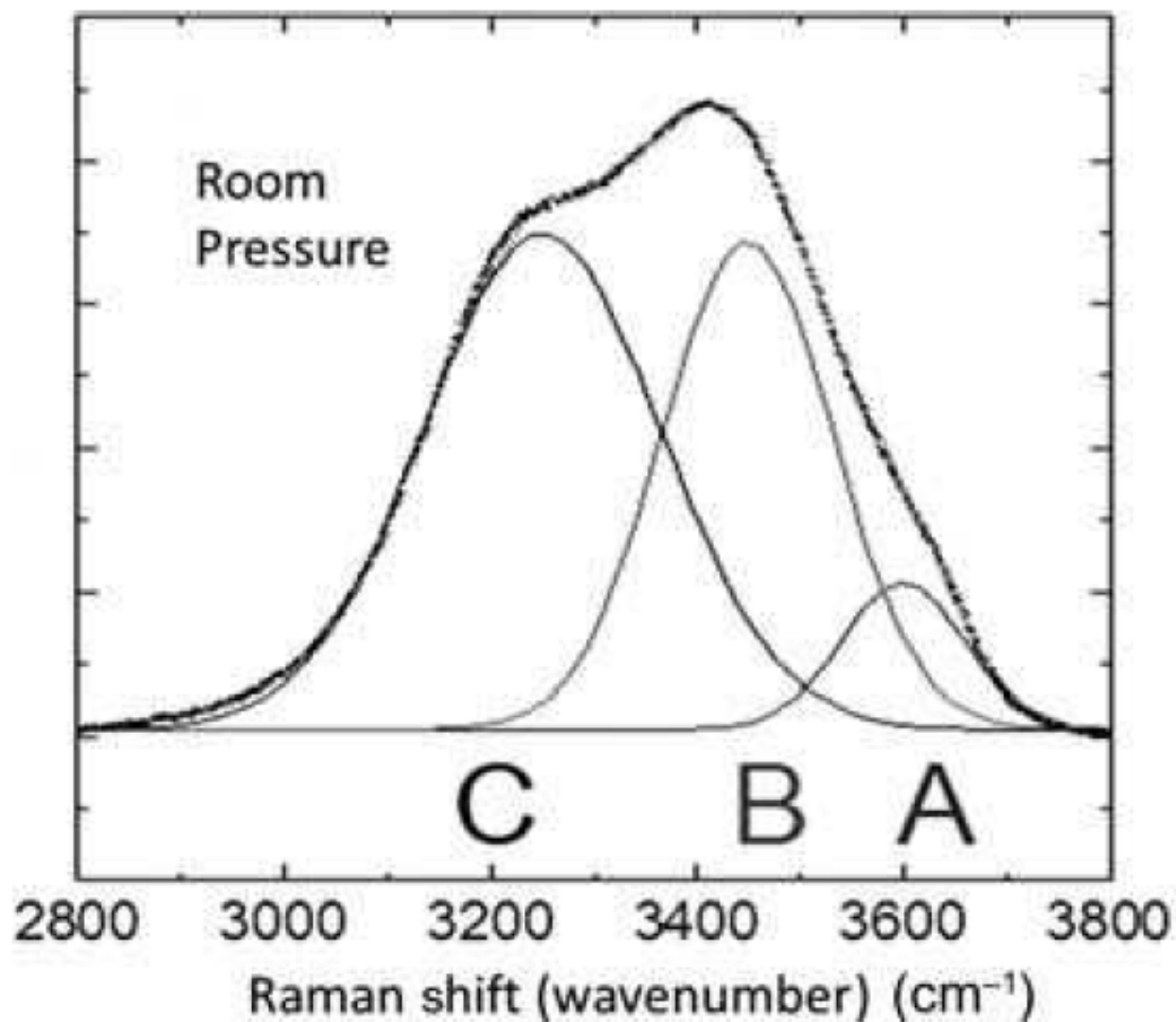

Garcia Baonza et al., EMU Notes vol.12, 2012

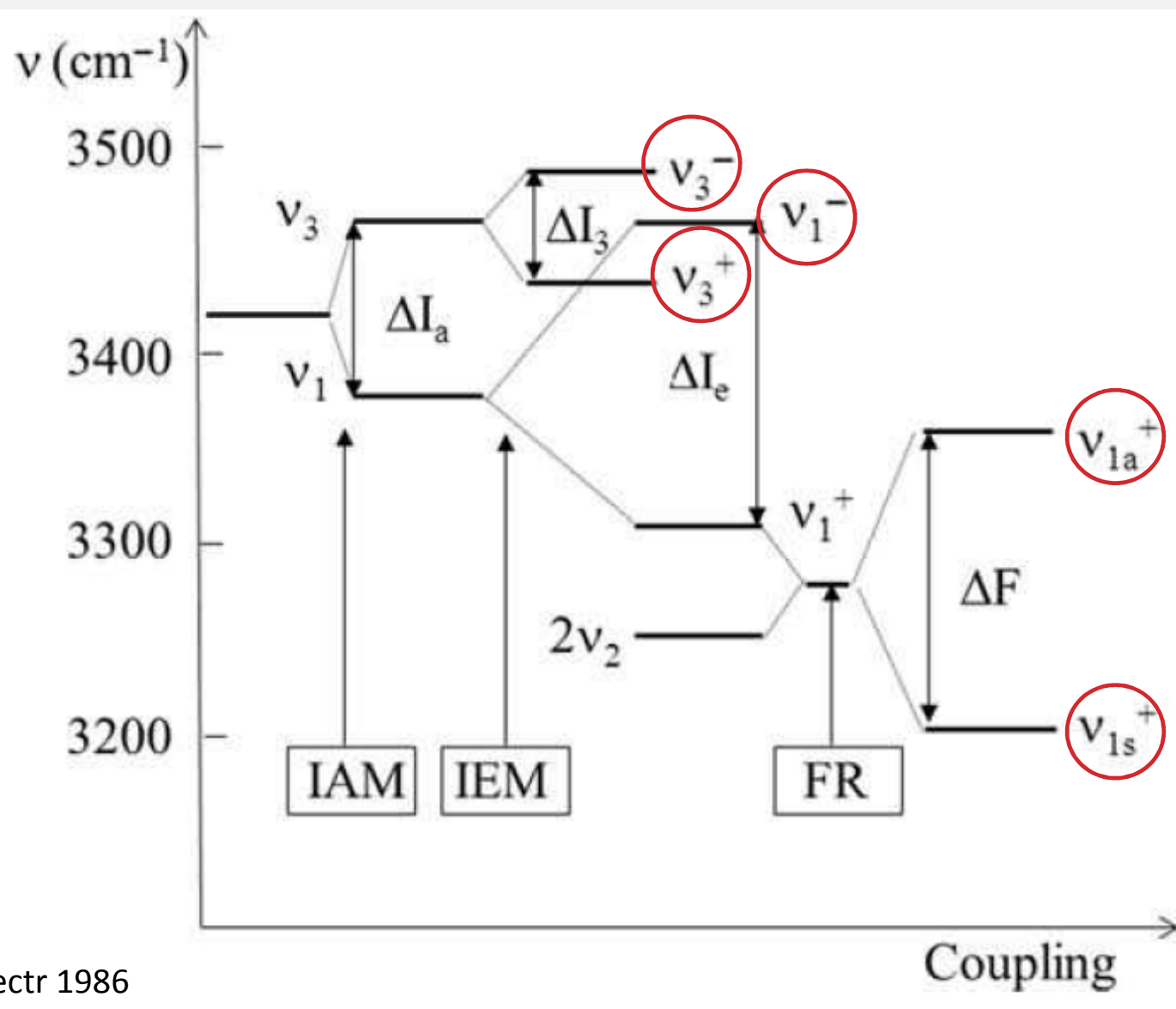

Rull & Saja J Raman Spectr 1986

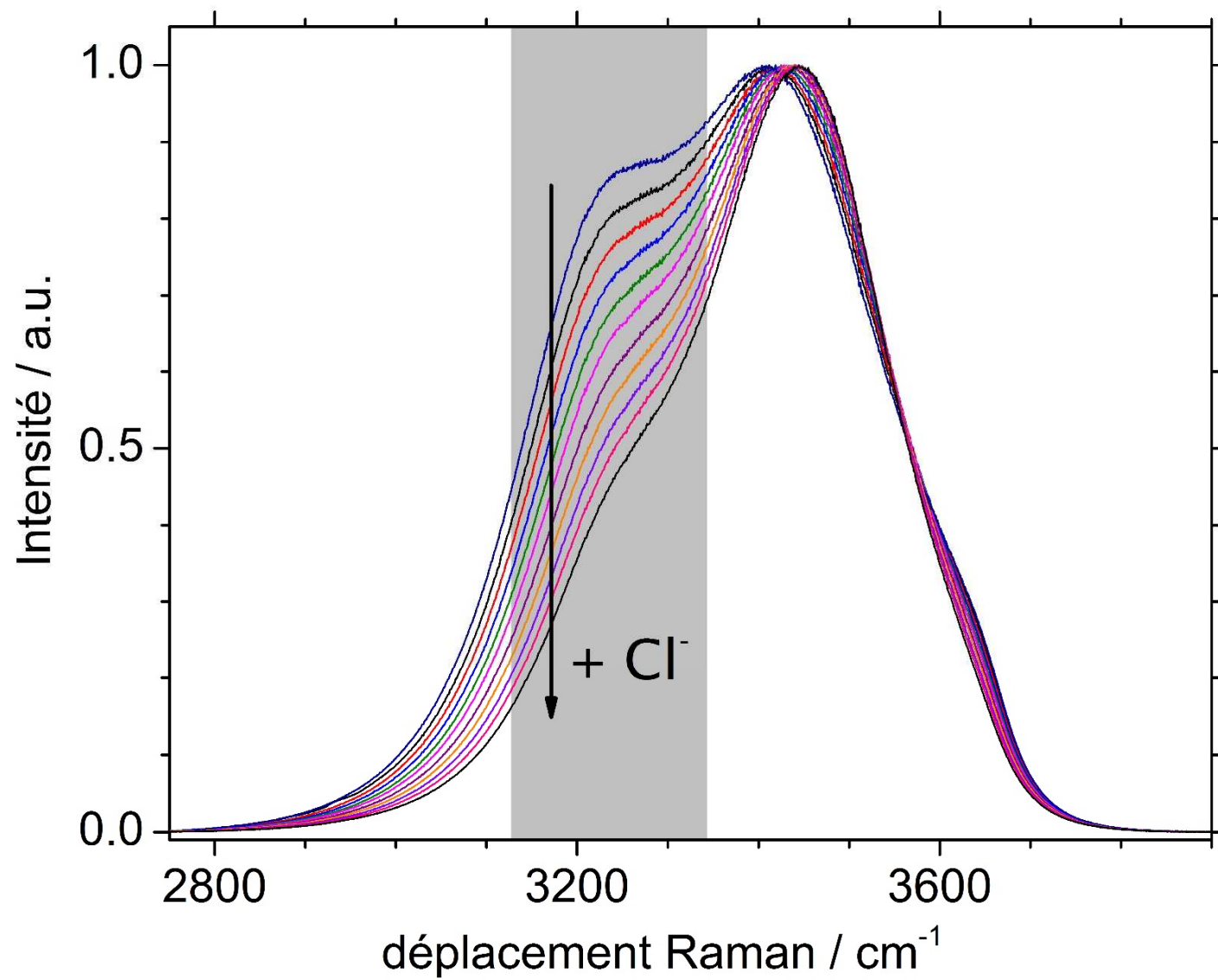

Chlorinity effect
on H-bonds.

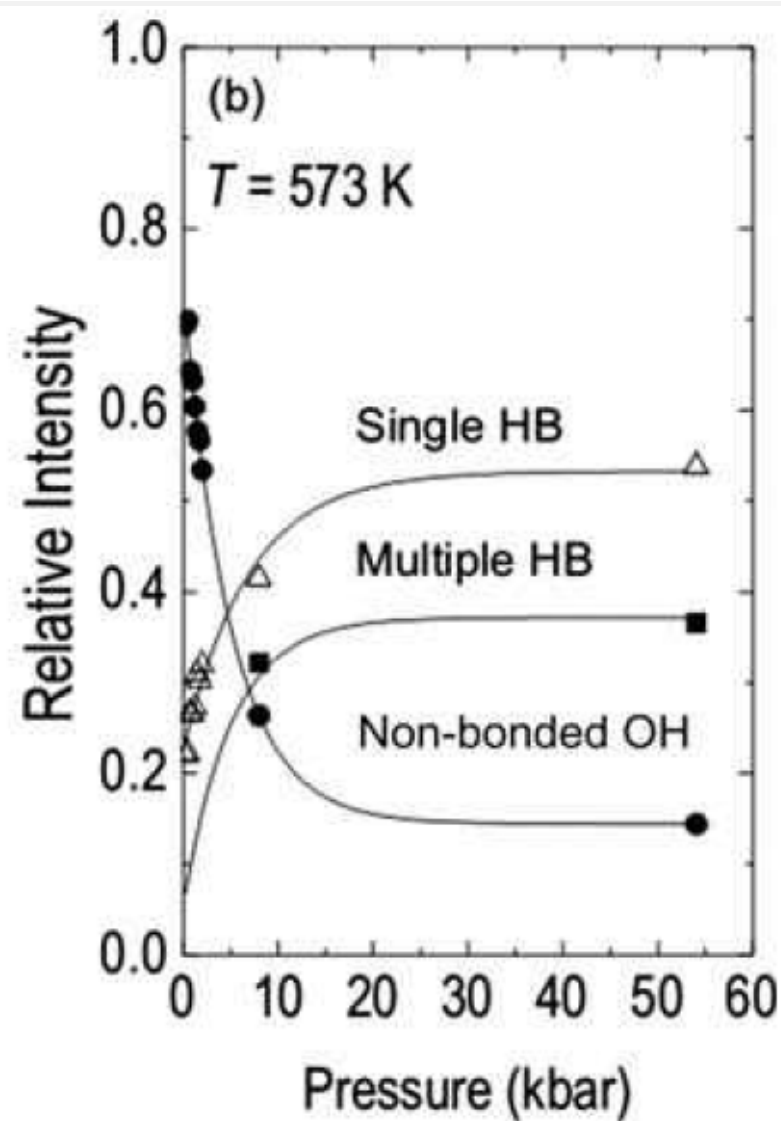
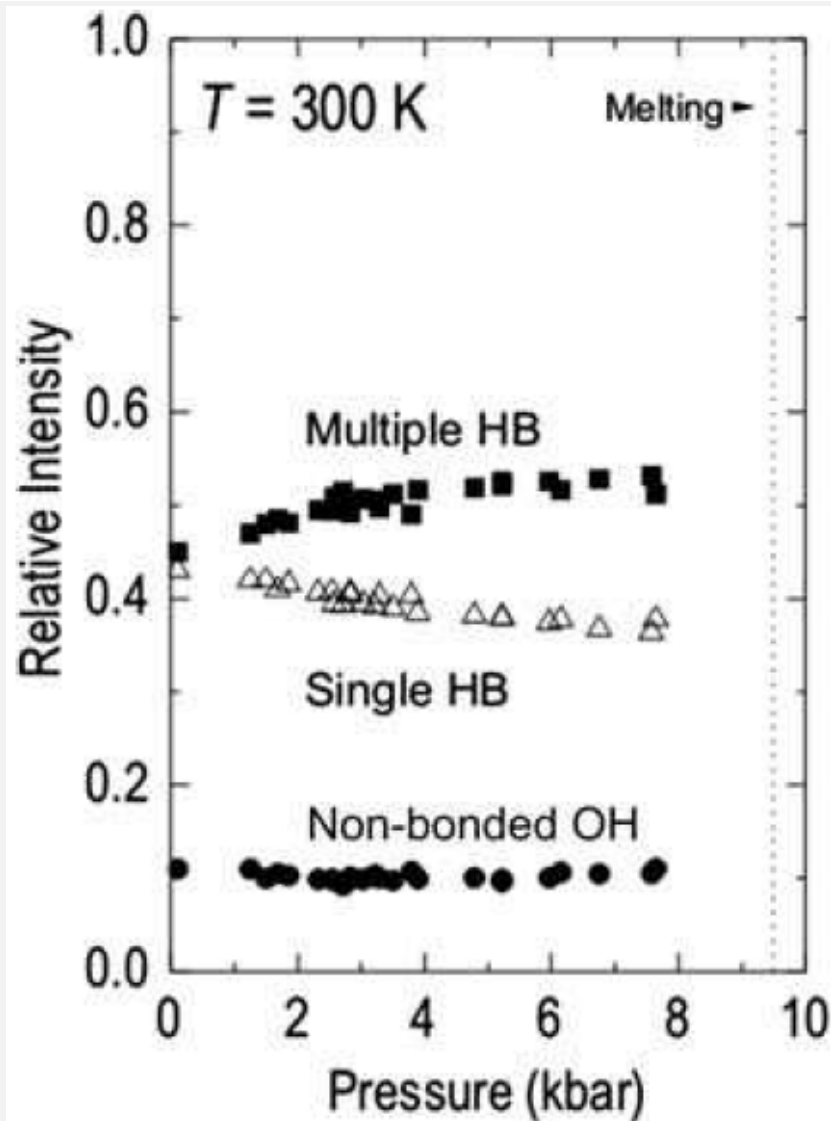

Garcia Baonza *et al.*, *EMU Notes vol.12*, 2012



Experimental devices for the study of geological fluids by Raman spectroscopy



1. Synthetic fluid inclusions

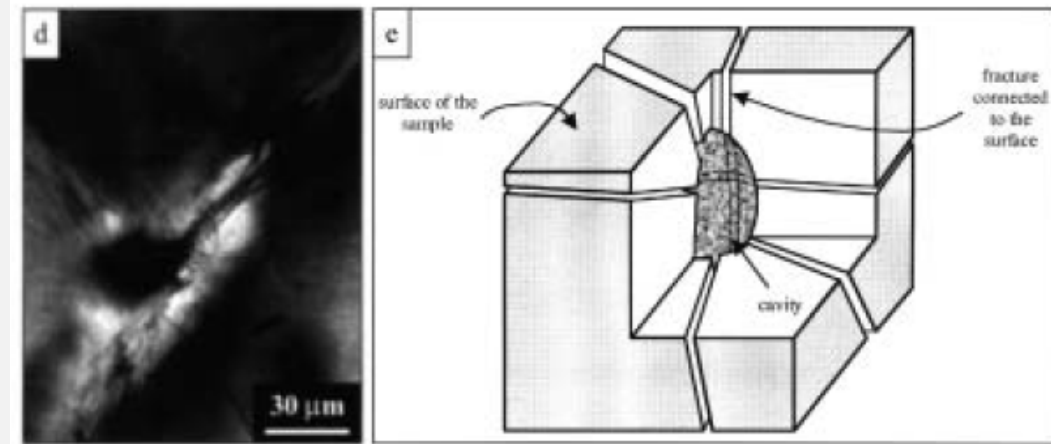
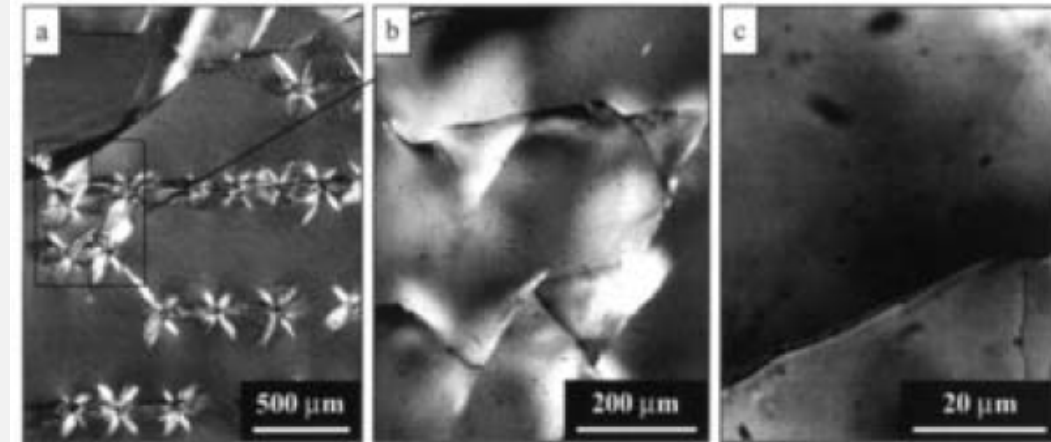
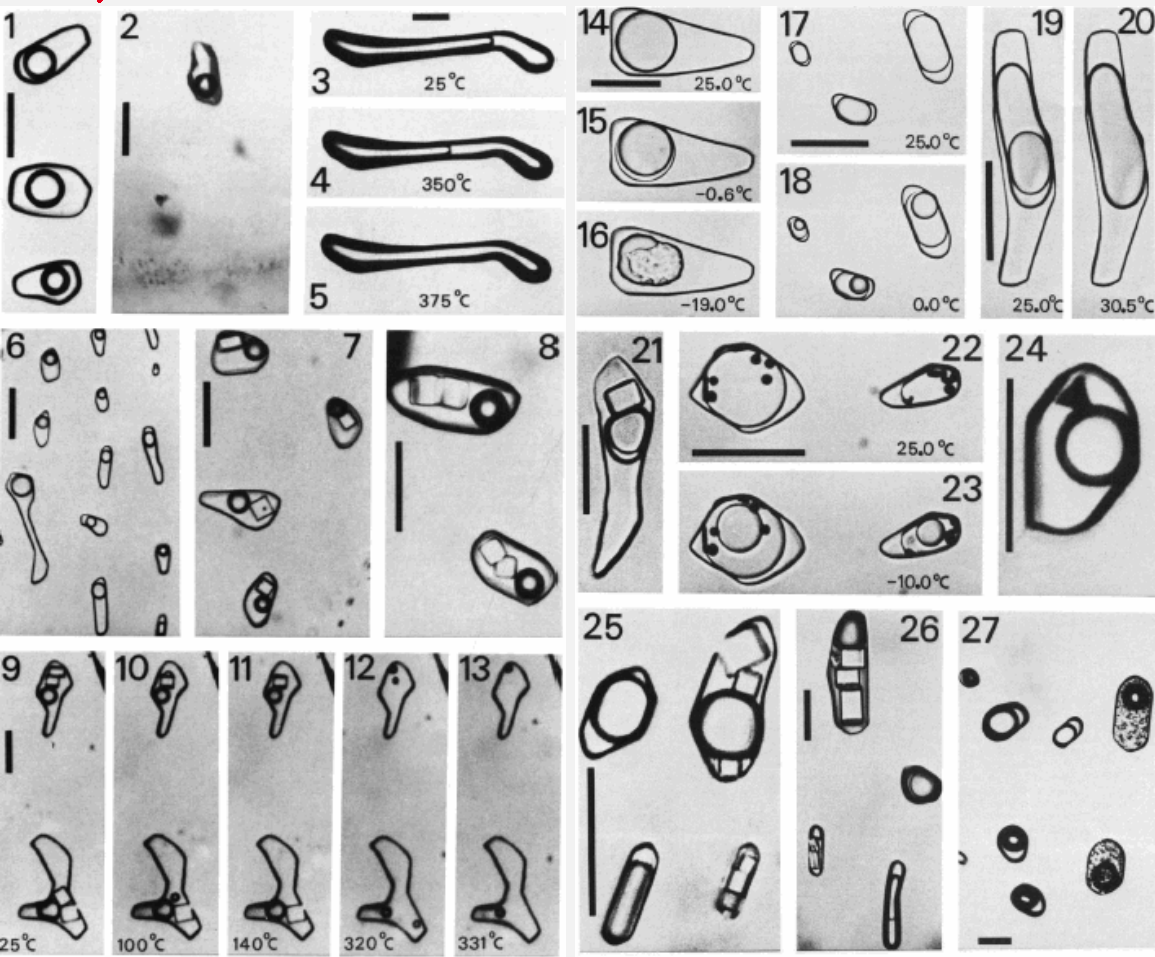

Creation of microcavities by laser ablation

From natural or lab-growth crystal (crack & heal)

Sterner & Bodnar, GCA 1984

Dubessy *et al.*, EJM 2000



2. autoclaves



With sapphire windows

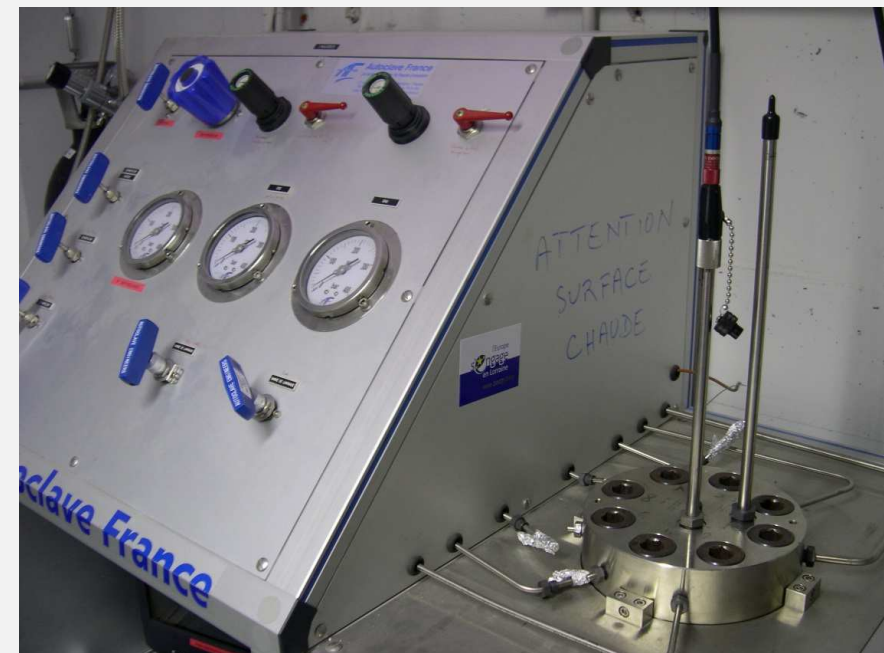

With immersion probes

5-200 bar
25-300 °C



Chou *et al.*, GCA 2008

3. Silica capillary cells

1-2000 bar
-196 – 400 °C

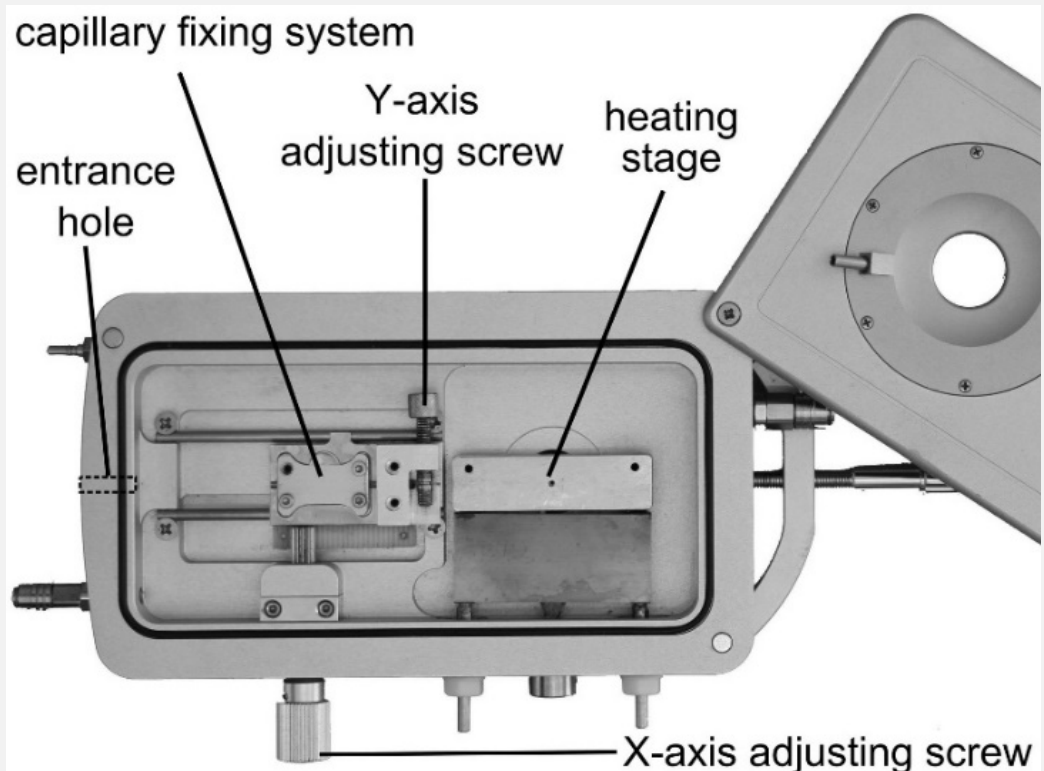
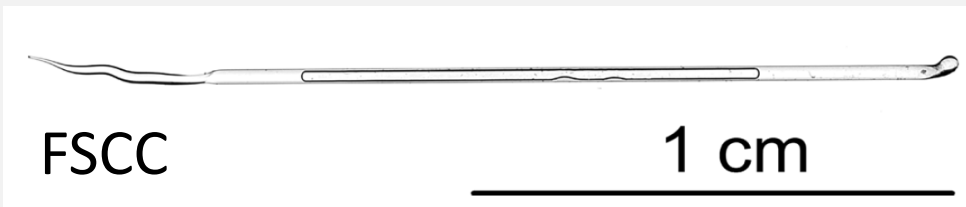

Geological fluids

Raman scattering cross sections

CO₂

H₂O

Experimental devices

Examples



4. HDAC

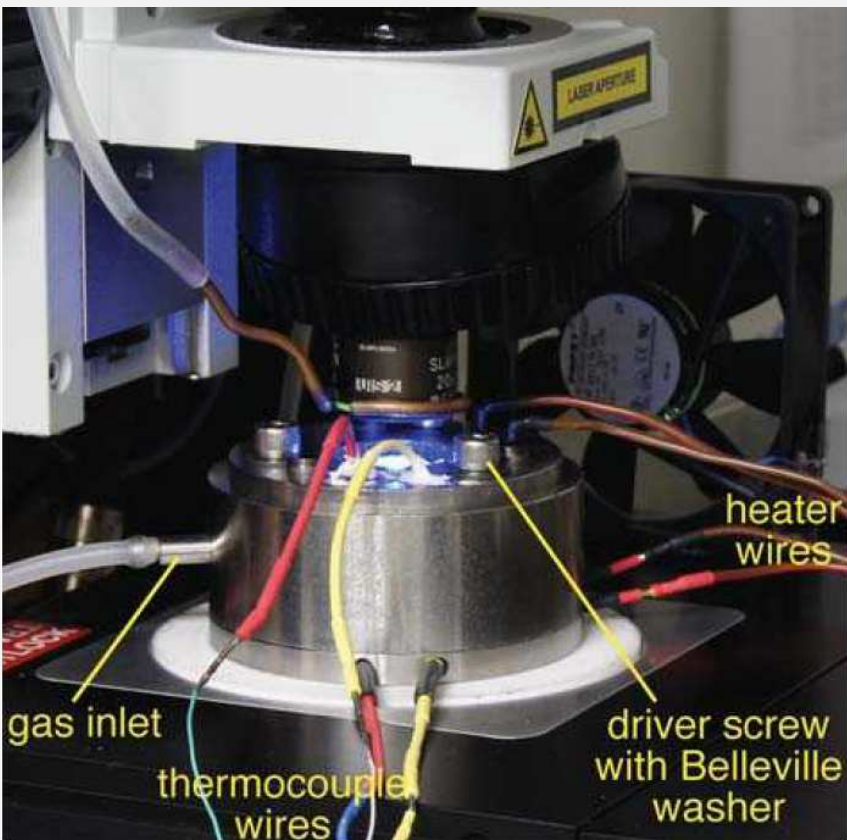

Up to ~1000 °C
1-20 GPa

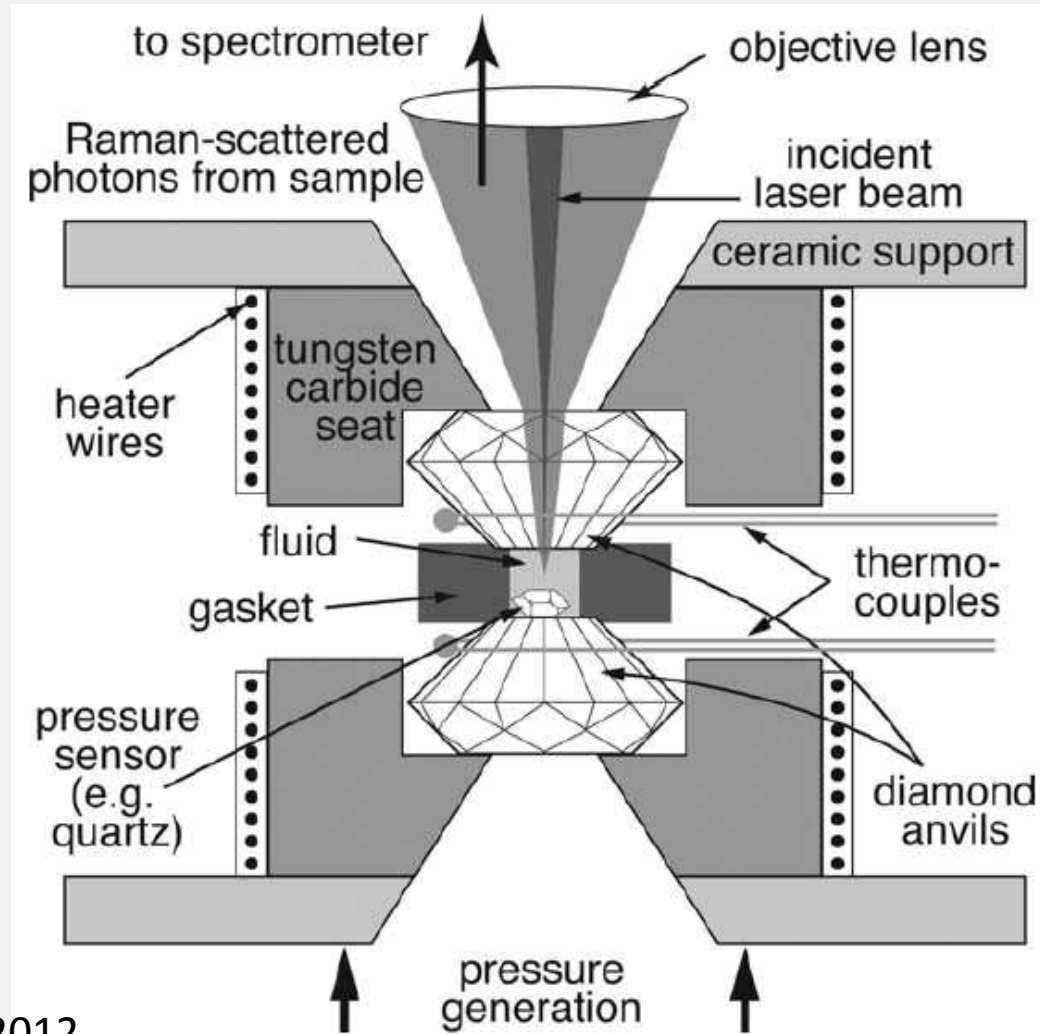

Schmidt & Chou, EMU Notes 12, 2012

Geological fluids

Raman scattering cross sections

CO₂

H₂O

Experimental devices

Examples



Some examples of geofluid studies by Raman spectroscopy



Gas solubility: CO₂

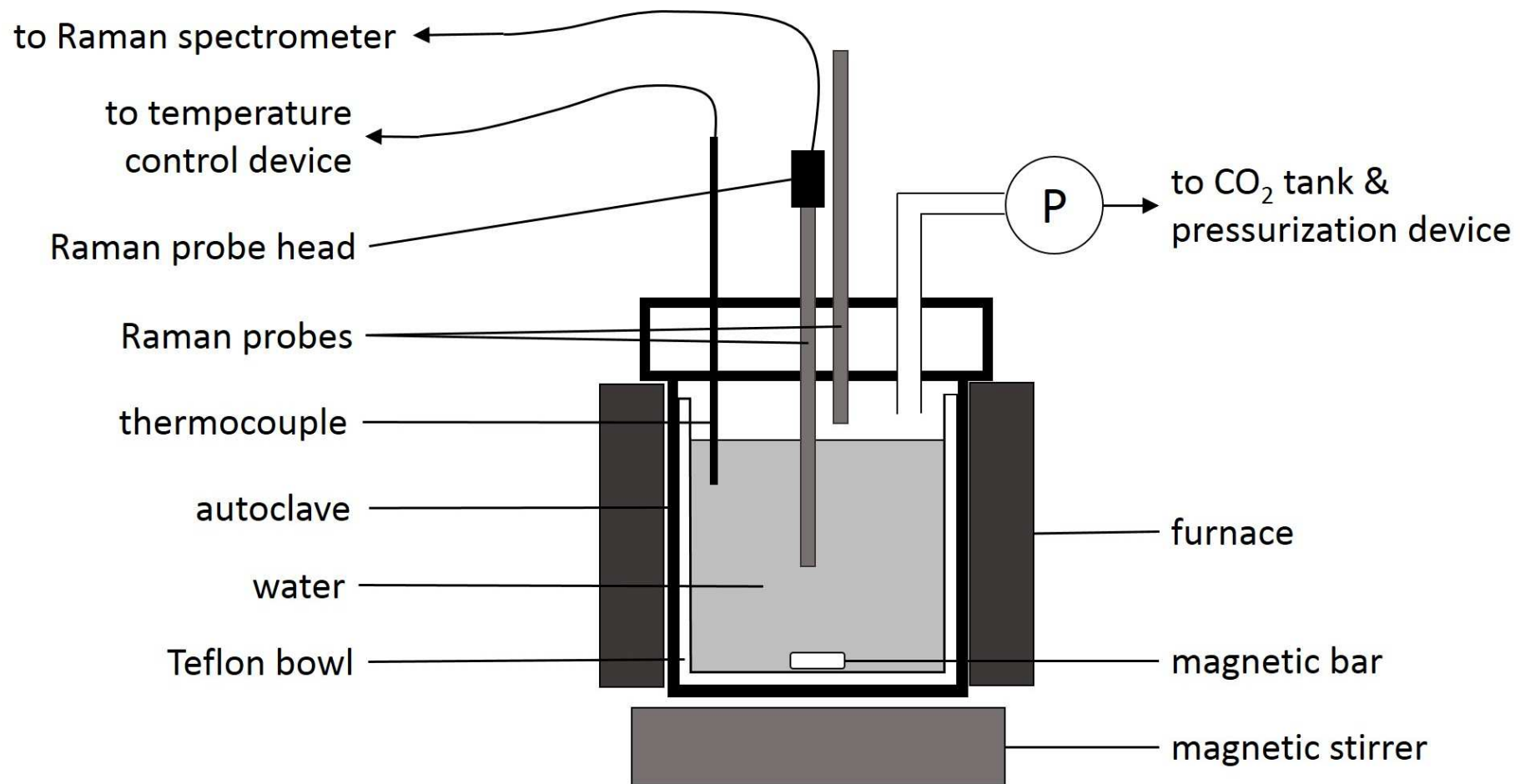

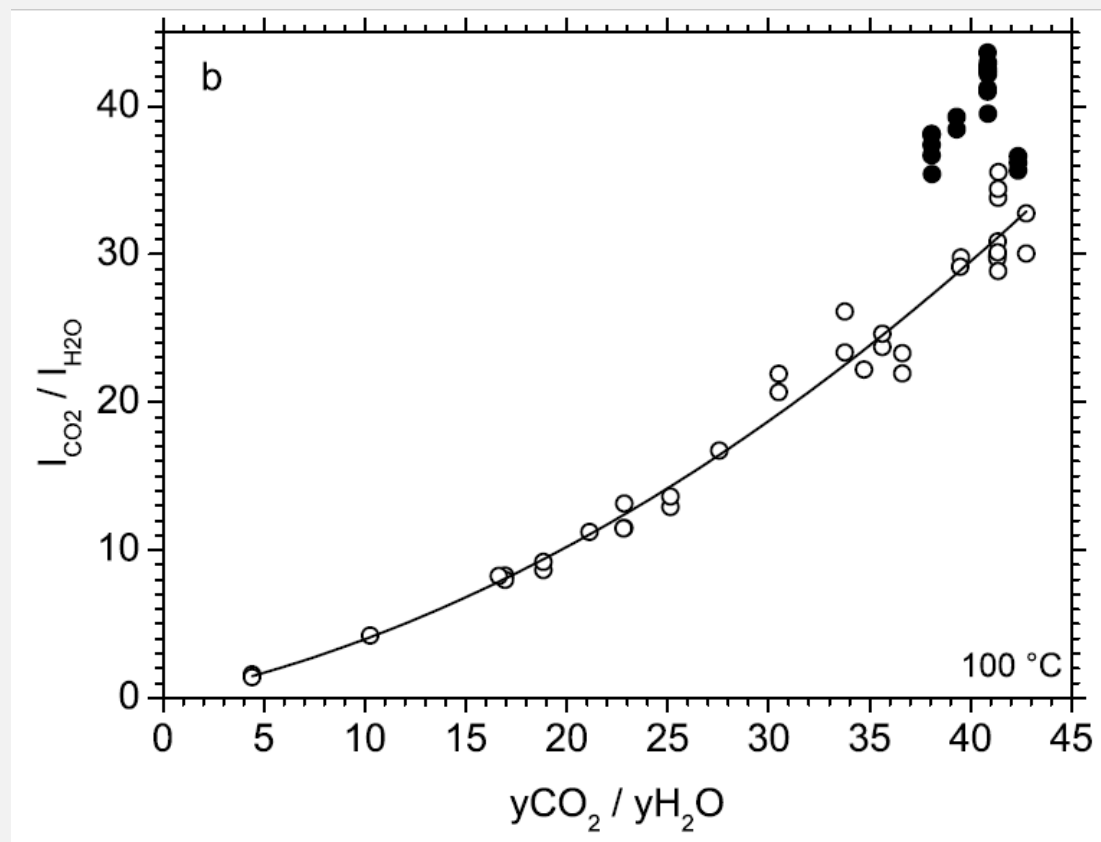
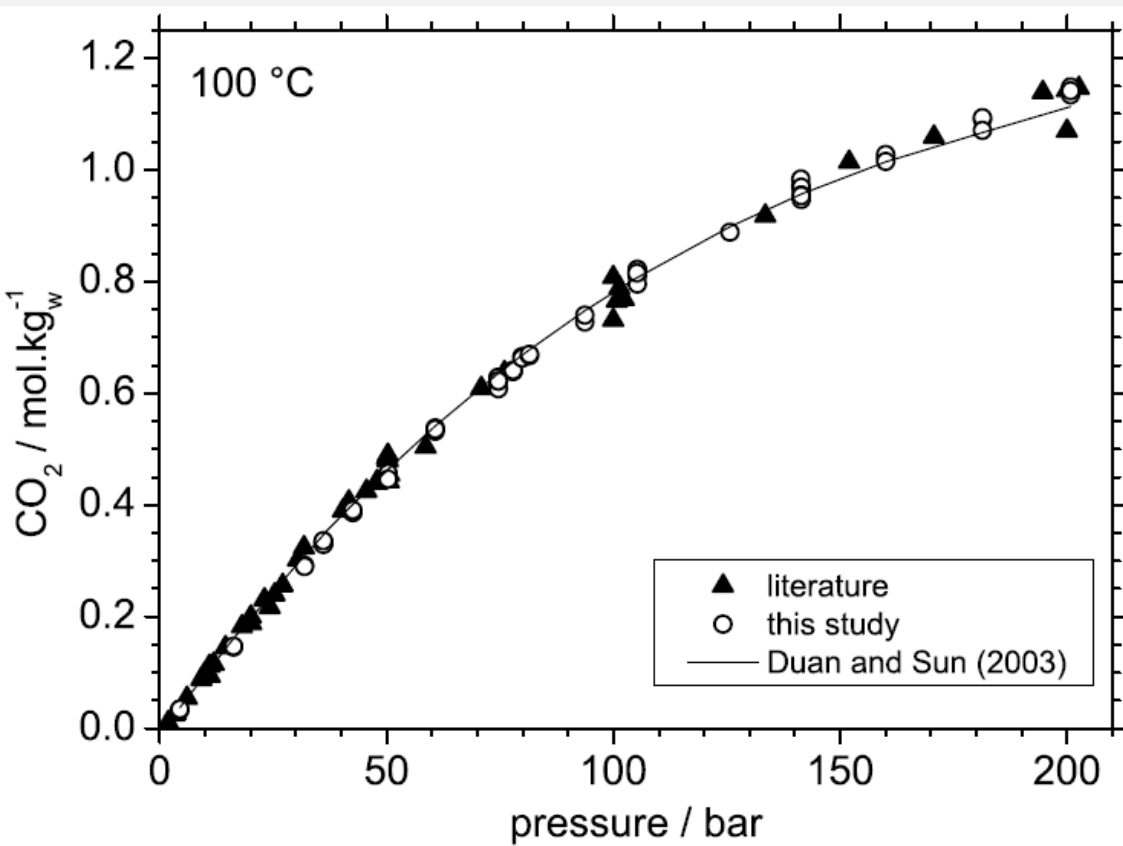

CO₂ solubility & pH vs. temperature and salinity

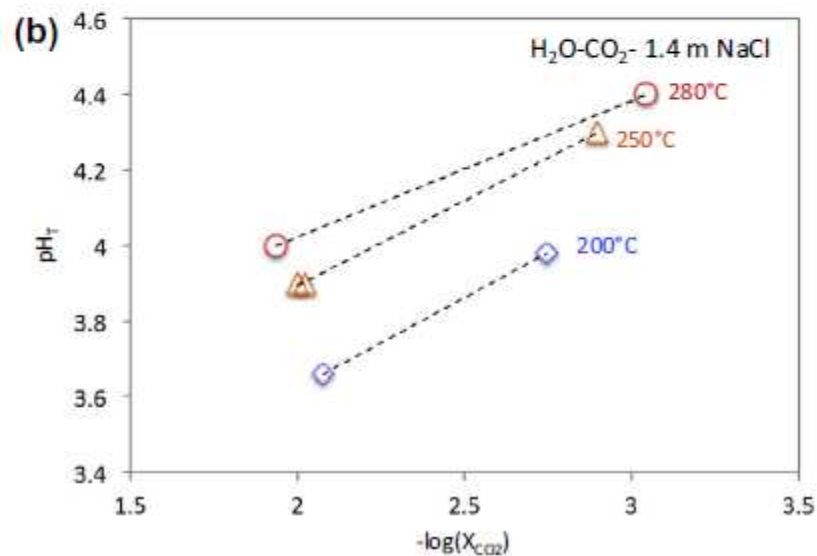
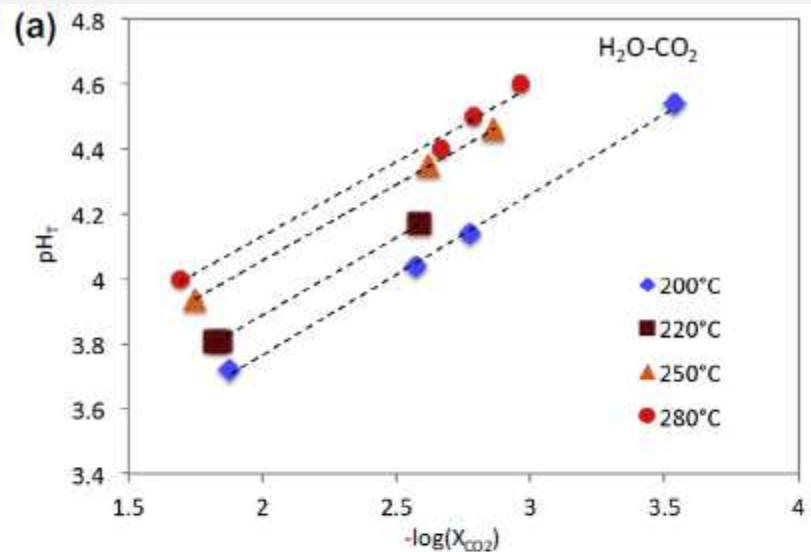
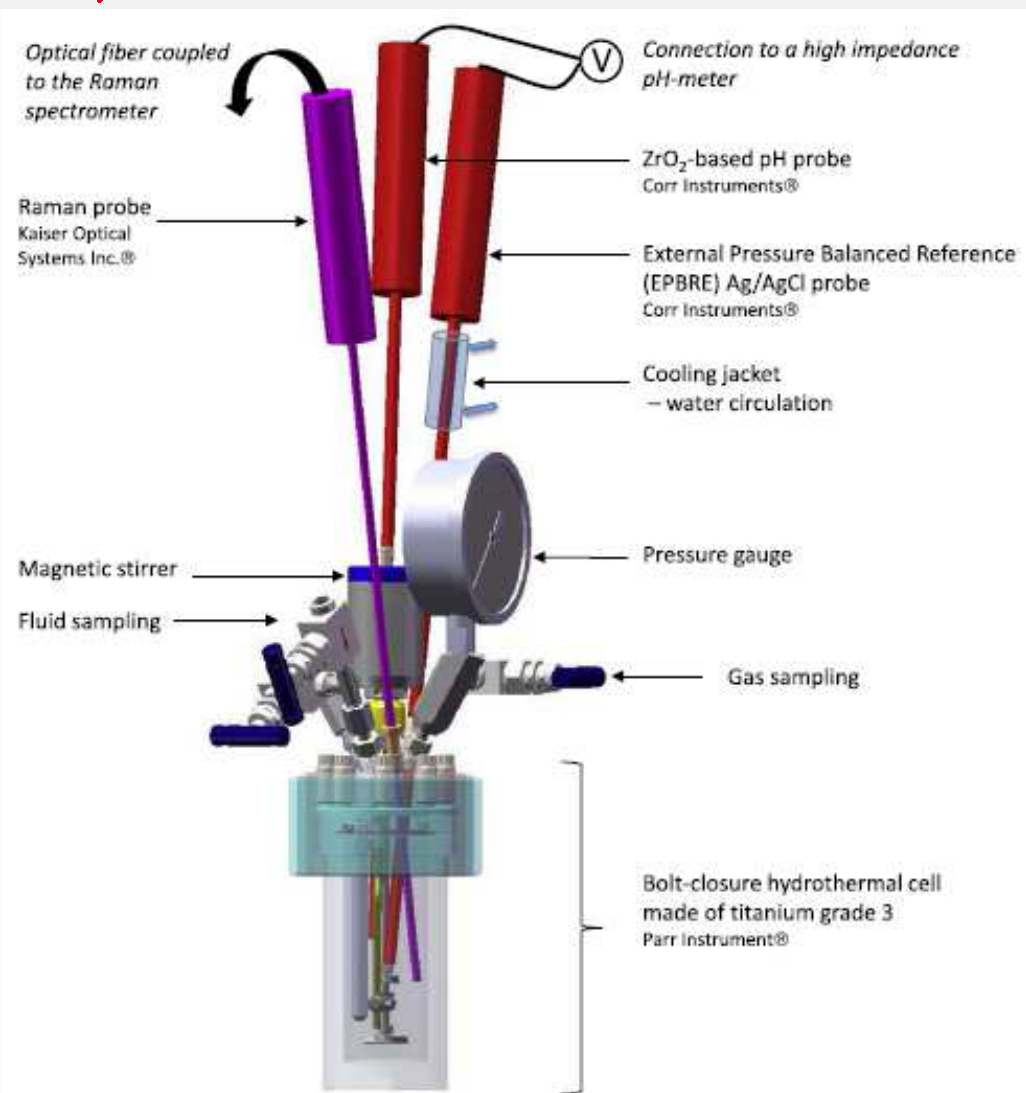

Truche *et al.*,
GCA 2016

Sulfur speciation vs. temperature

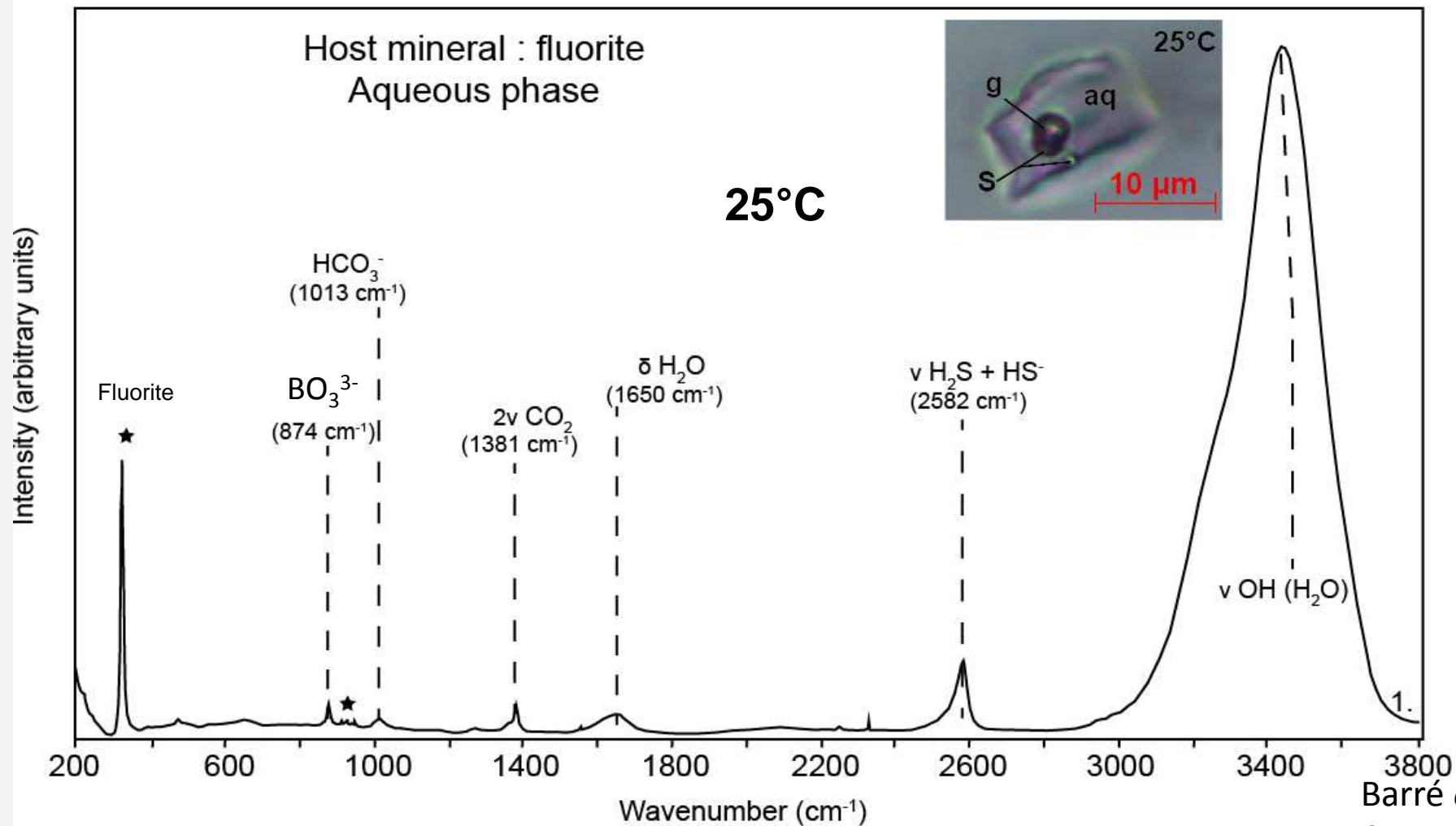

Barré *et al.*, SGA 2015
& Geology (submitted)

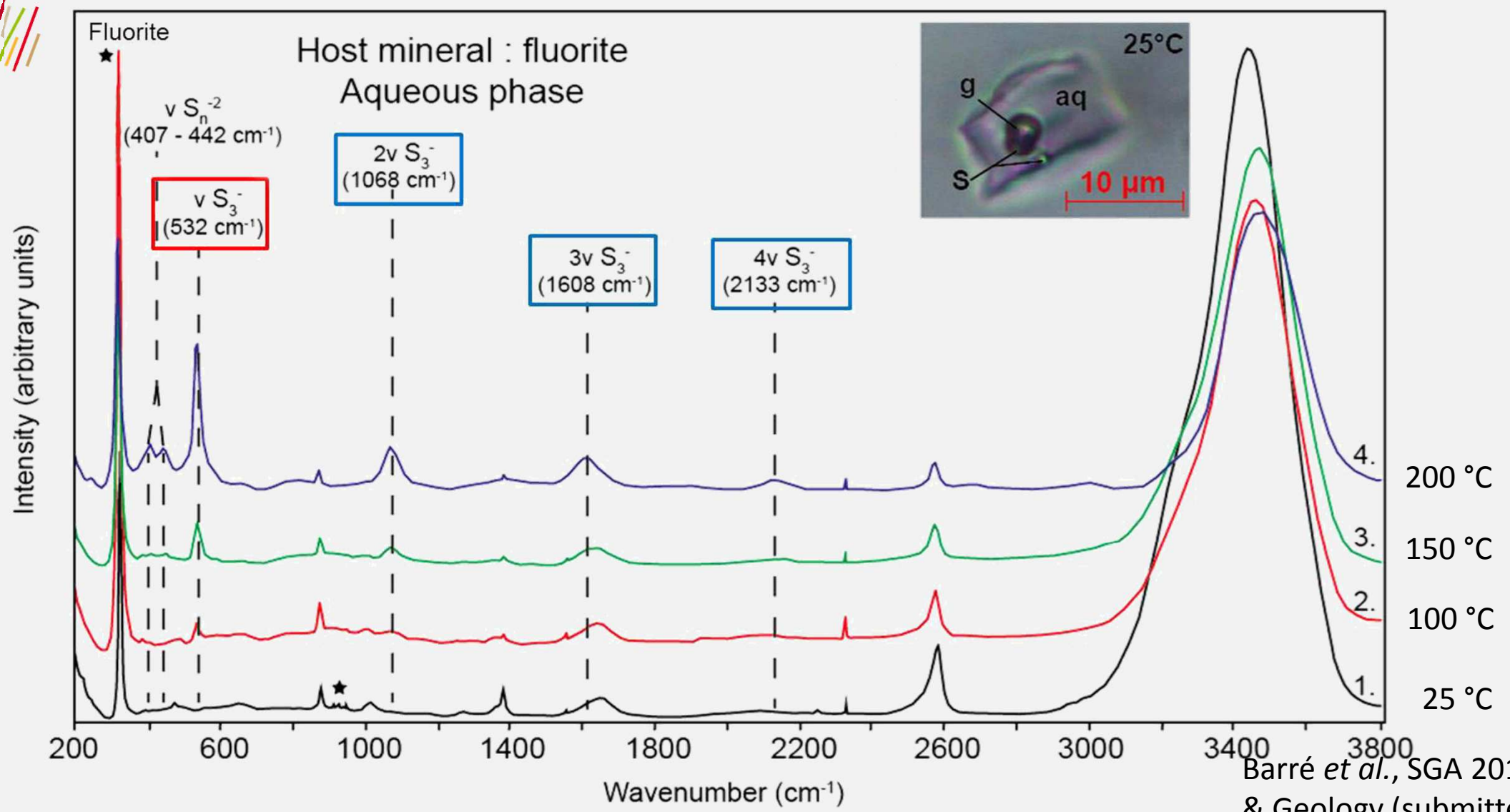



Standard solutions :

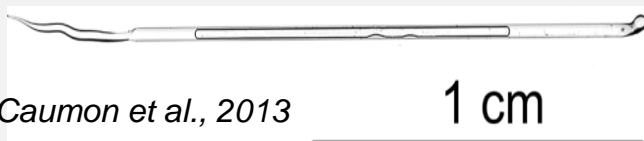
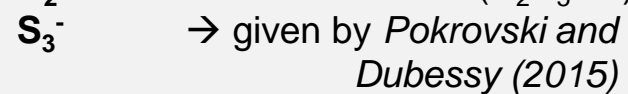
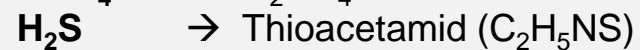
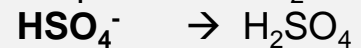
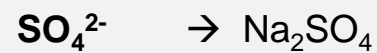

Caumon et al., 2013

1 cm

Barré et al., SGA 2015
& Geology (submitted)

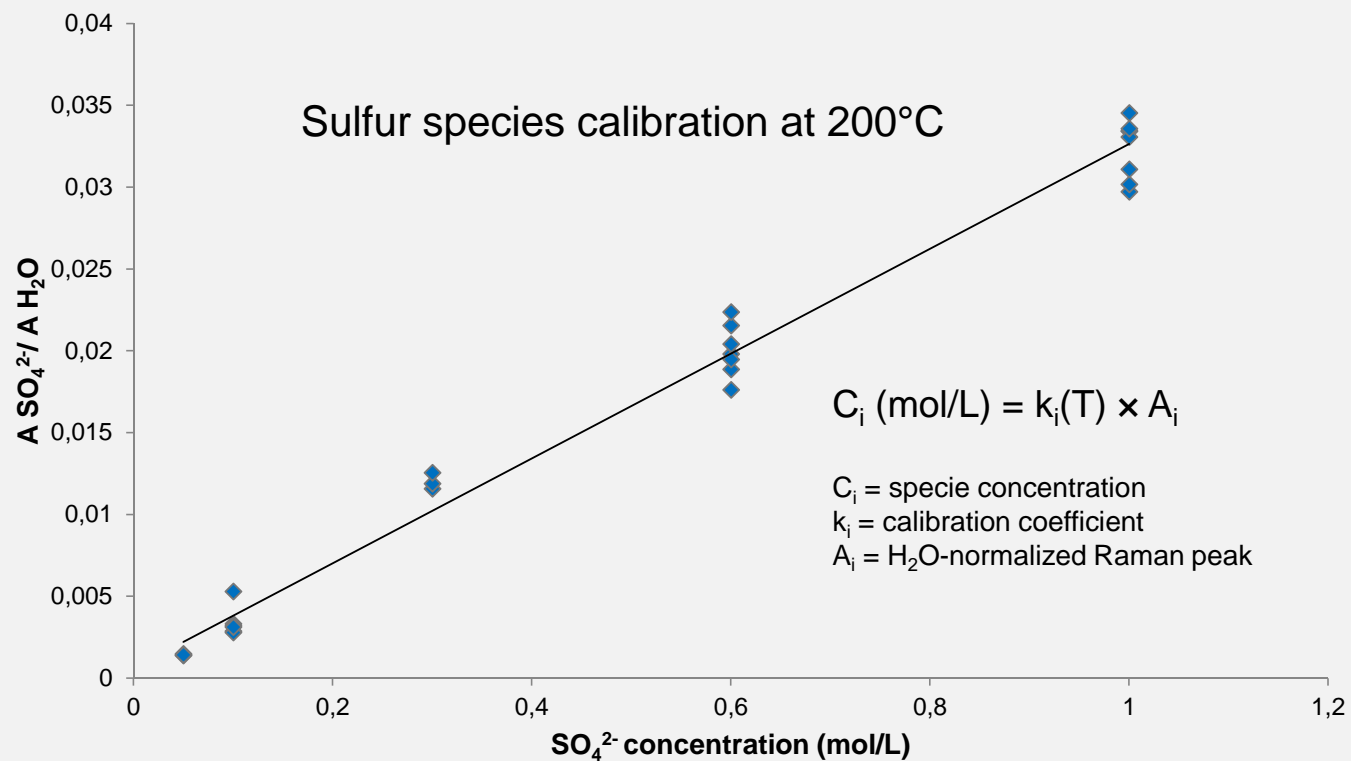



Natural fluid inclusions

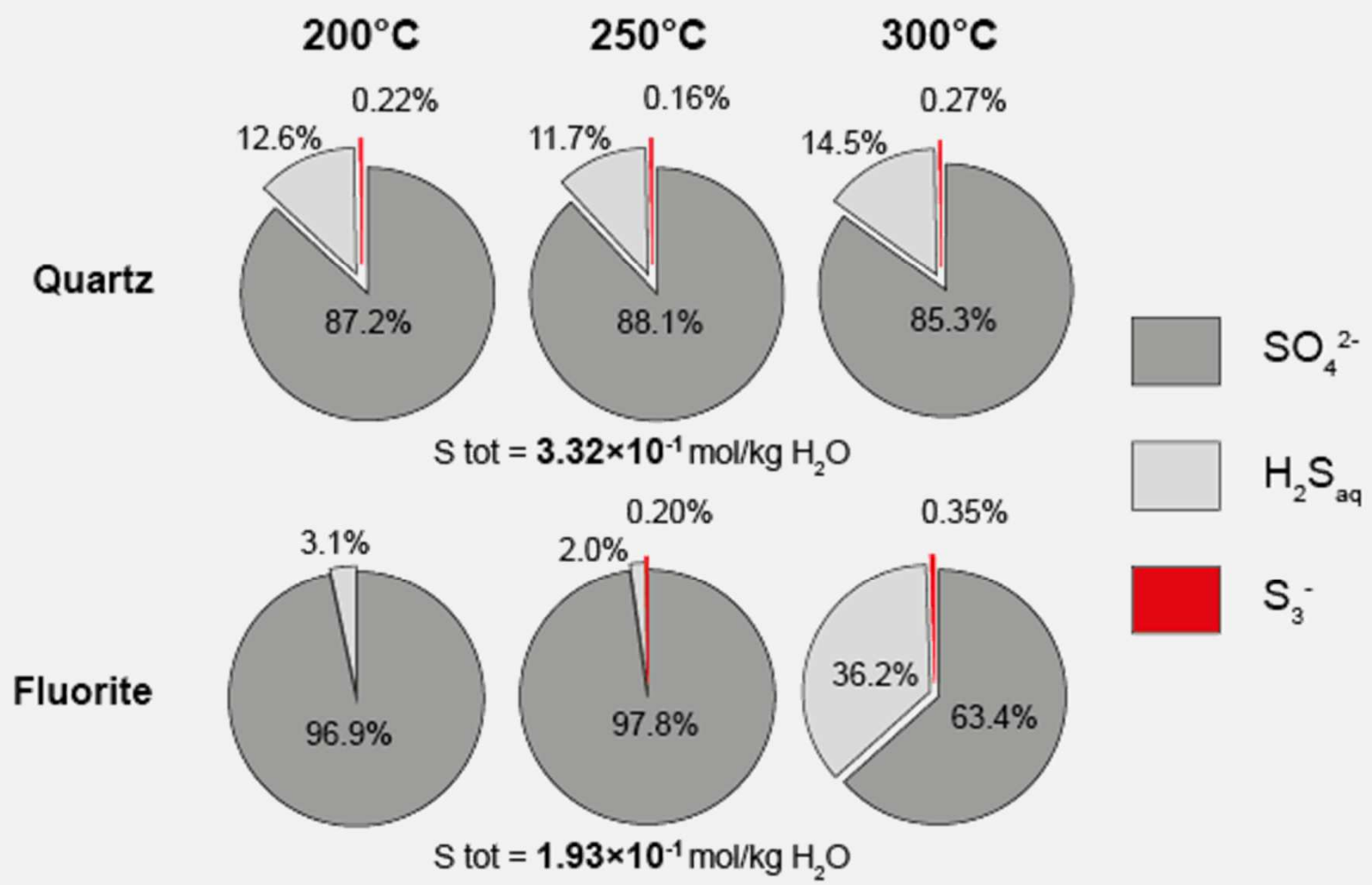

Barré *et al.*, SGA 2015
& Geology (submitted)

Uranyl speciation in LiCl solutions

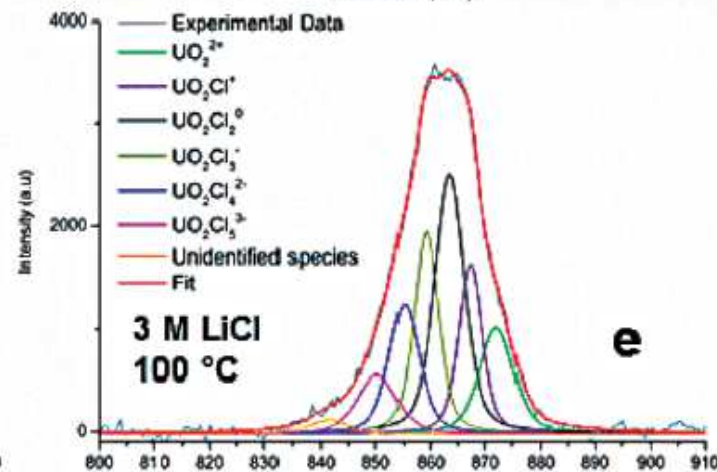
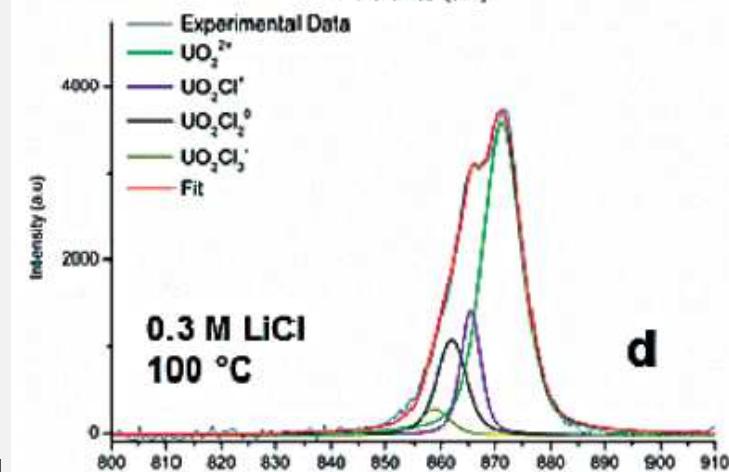
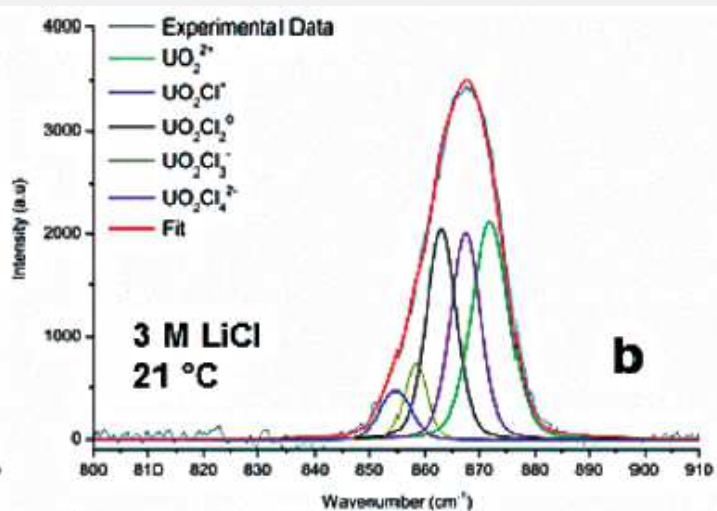
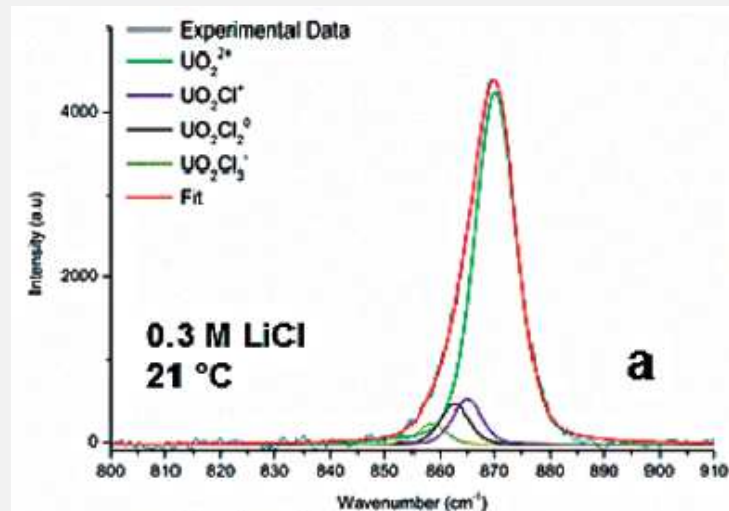
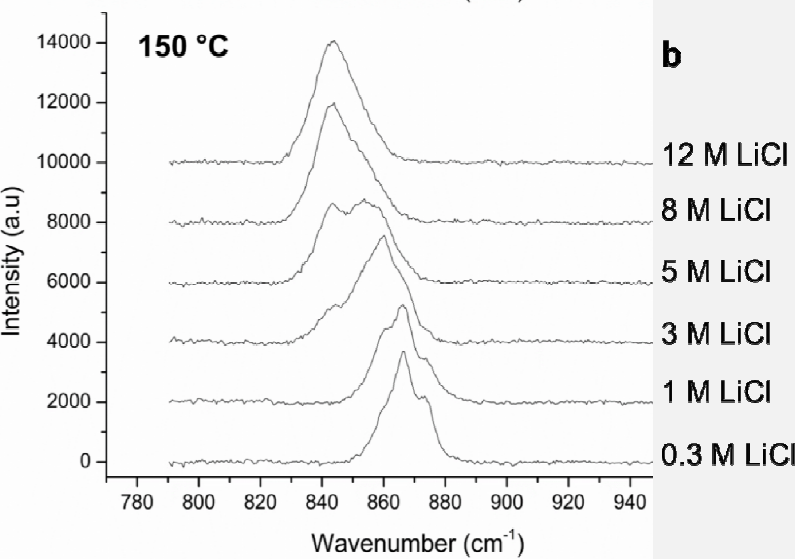
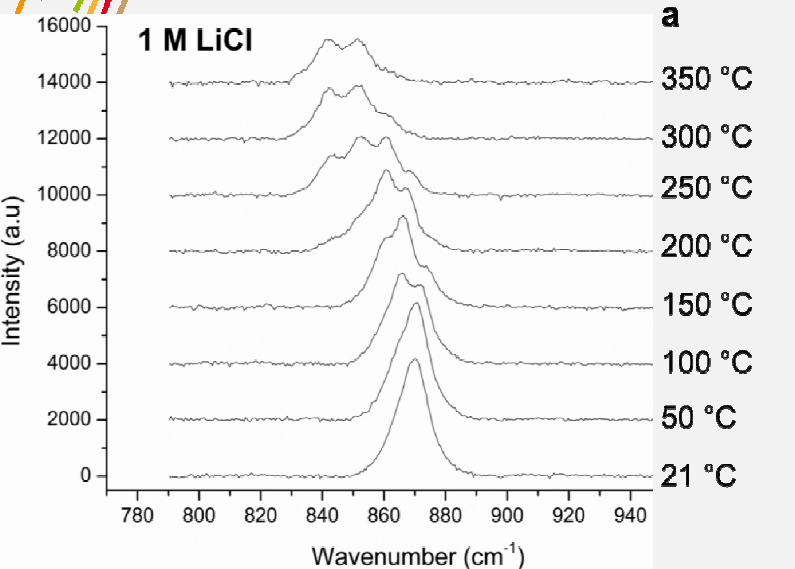

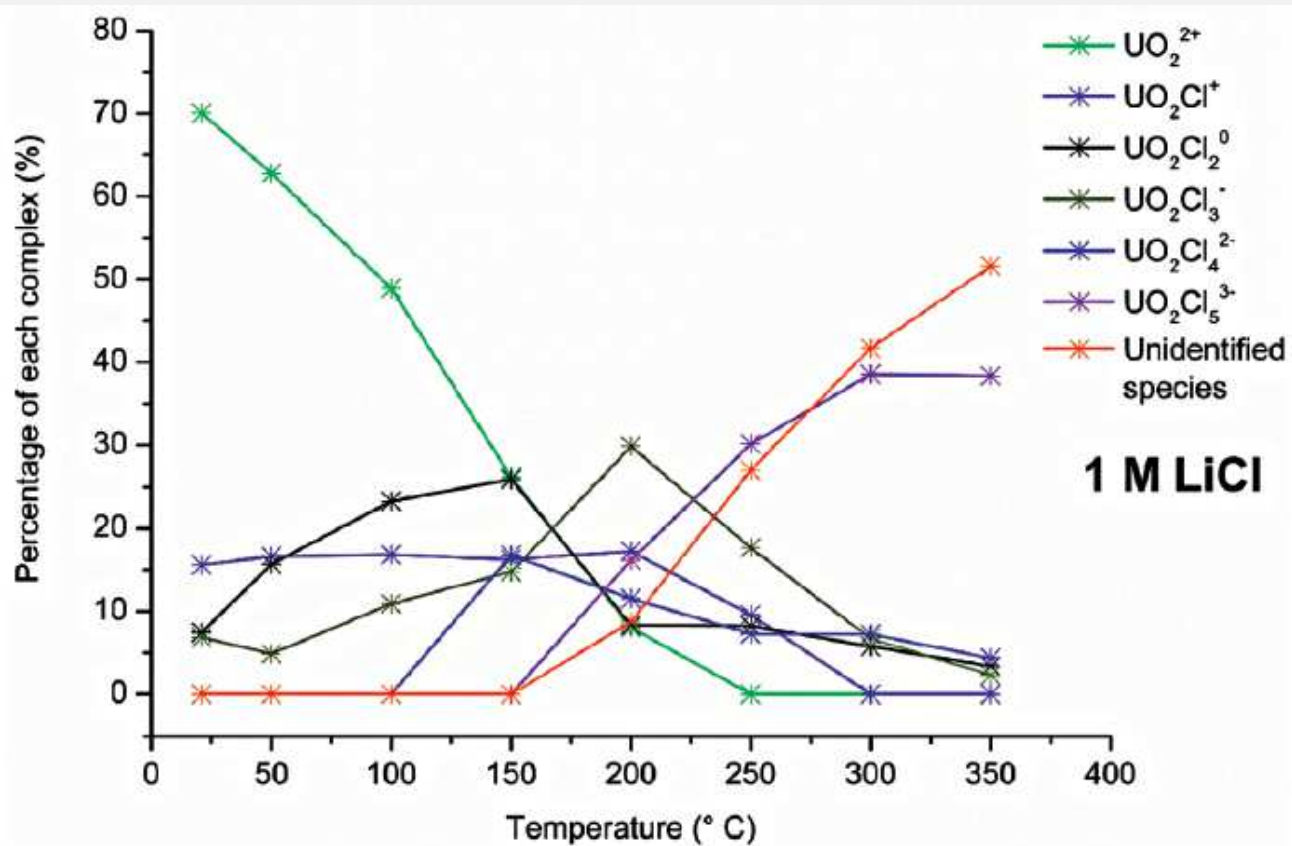

Speciation diagram vs. temperature and LiCl concentration



Calculation of equilibrium constants K_{n+1}
$$\text{UO}_2\text{Cl}_n^{2n}(\text{aq}) + \text{Cl}^-_{(\text{aq})} = \text{UO}_2\text{Cl}_{n+1}^{1n}(\text{aq})$$

Diffusion of CO₂ in water

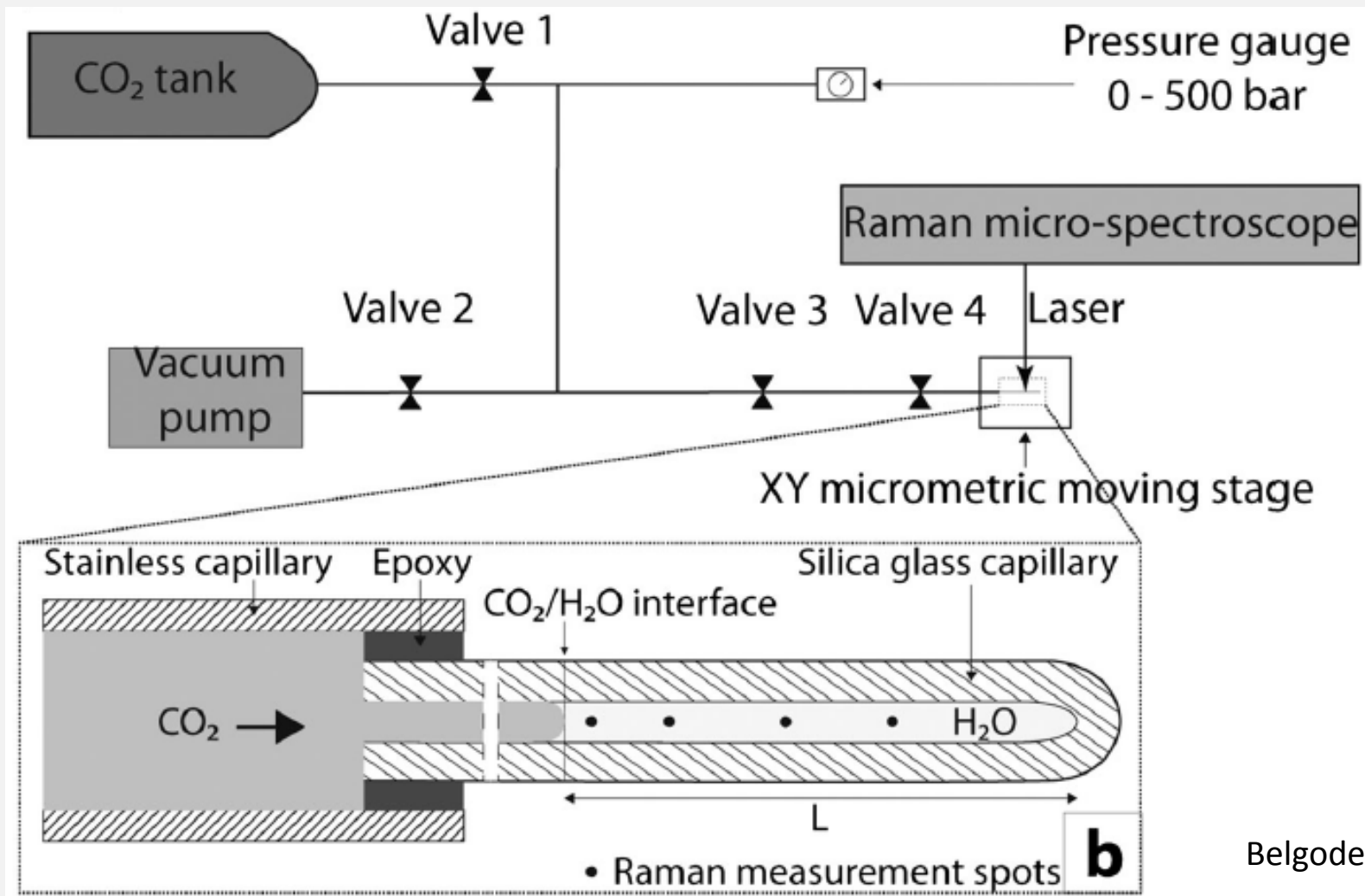

Belgodere *et al.*, J Raman Spectr 2015

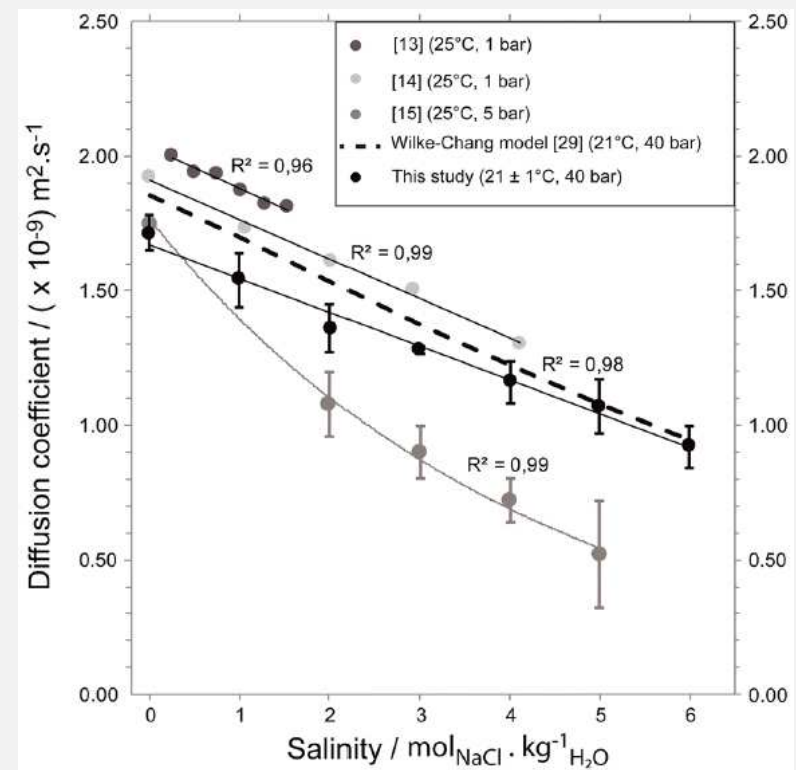
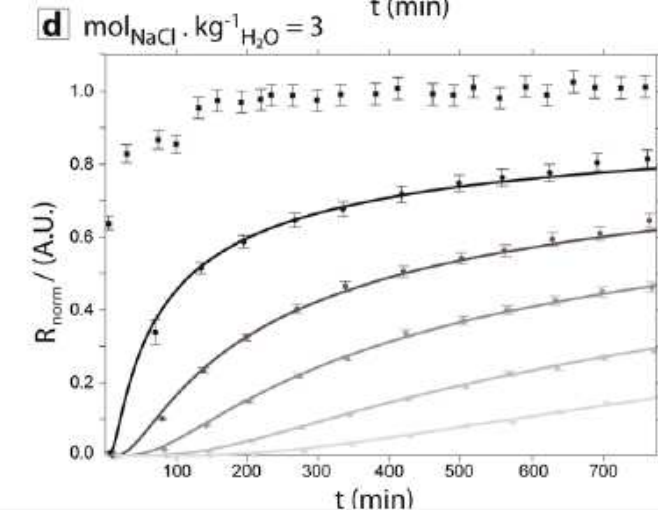
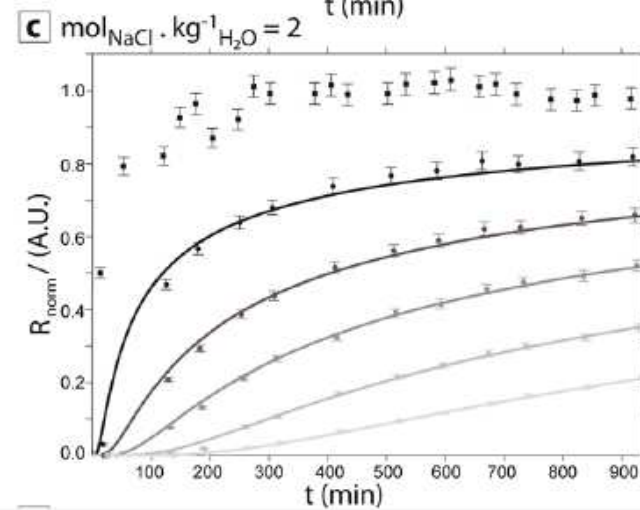
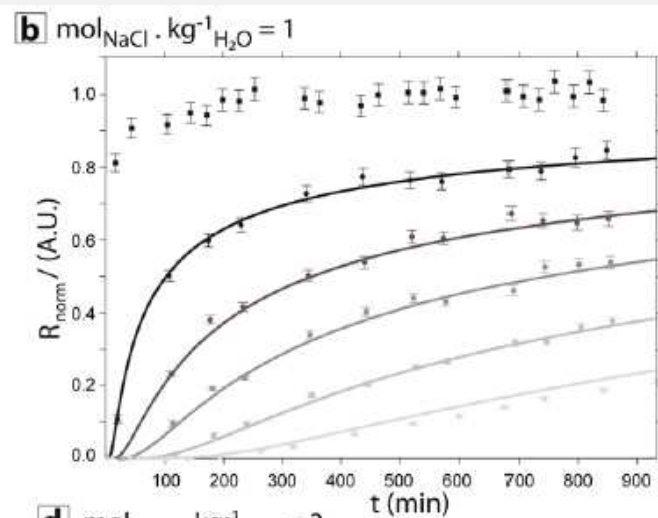
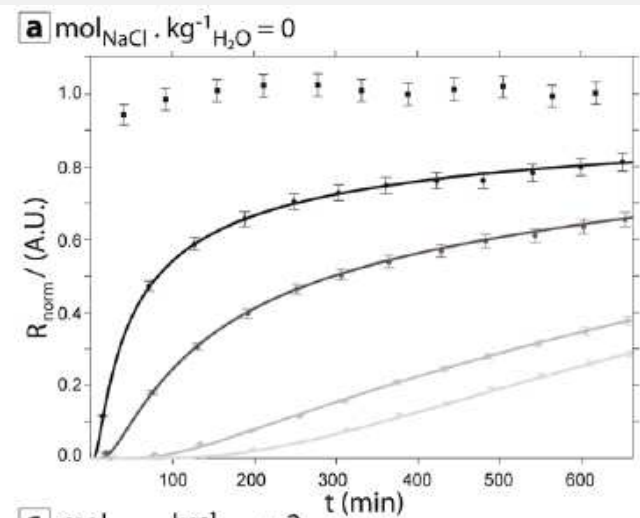



Salinity of fluid inclusions

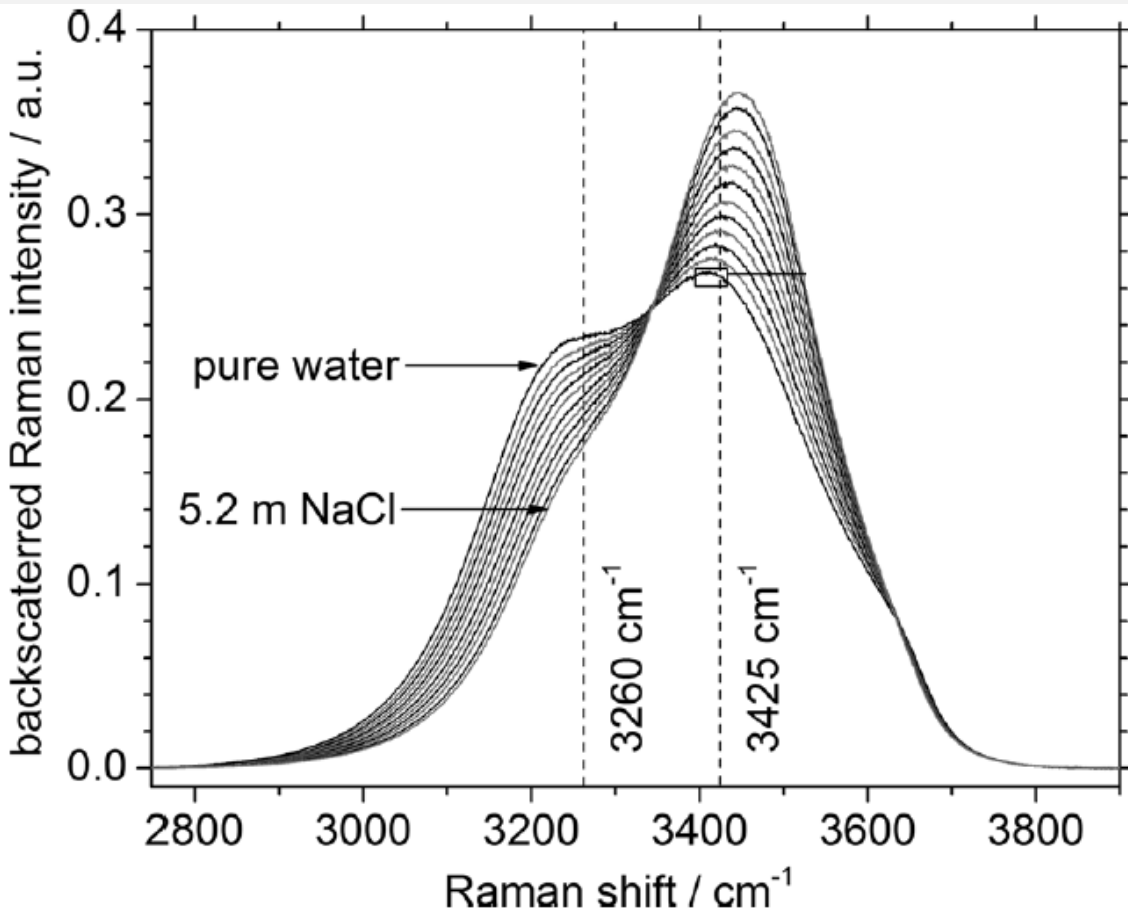

Caumon *et al.*, EJM 2013

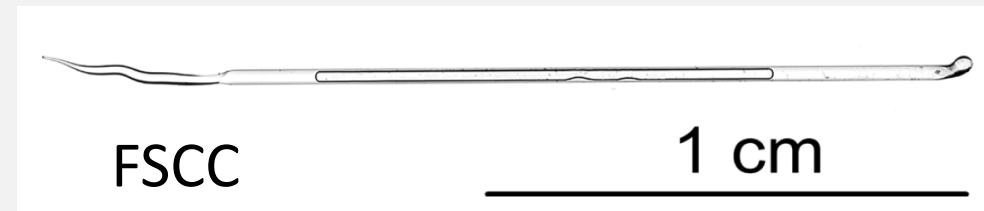

Fused Silica Capillary Capsules

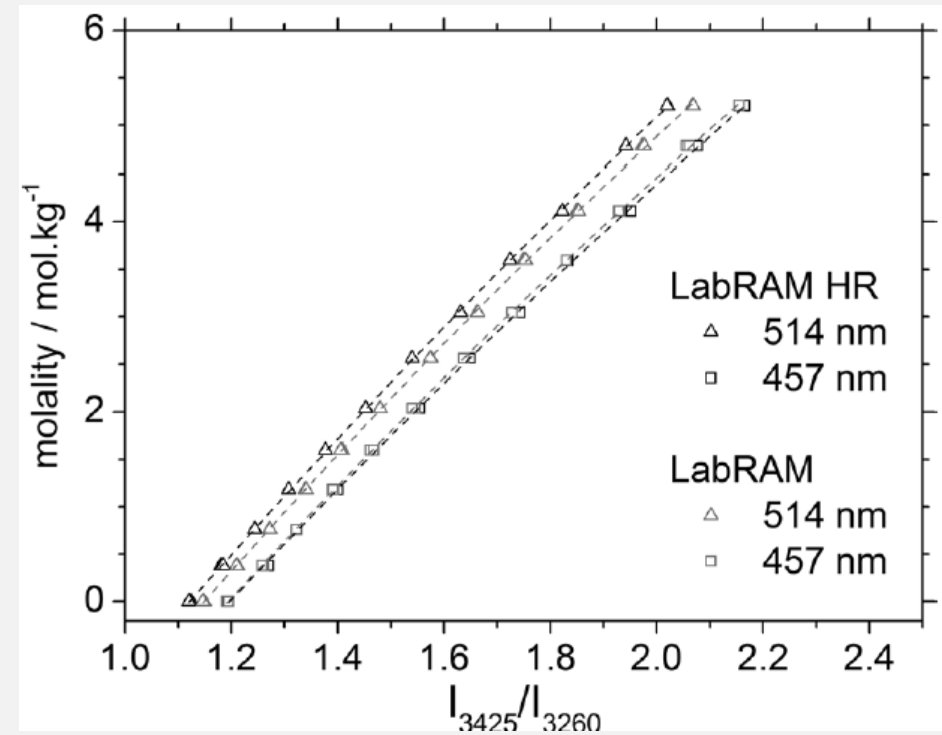

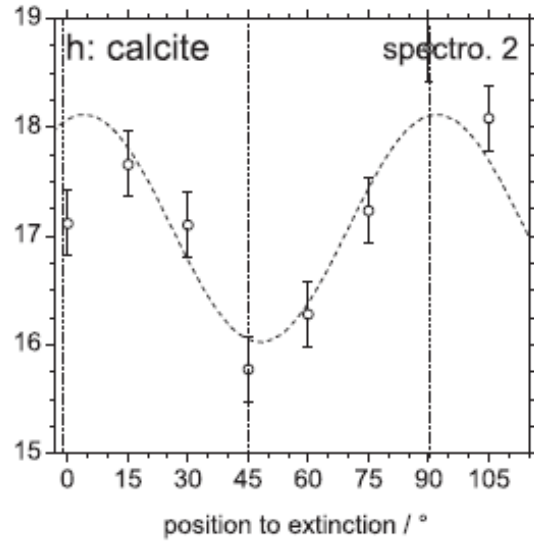
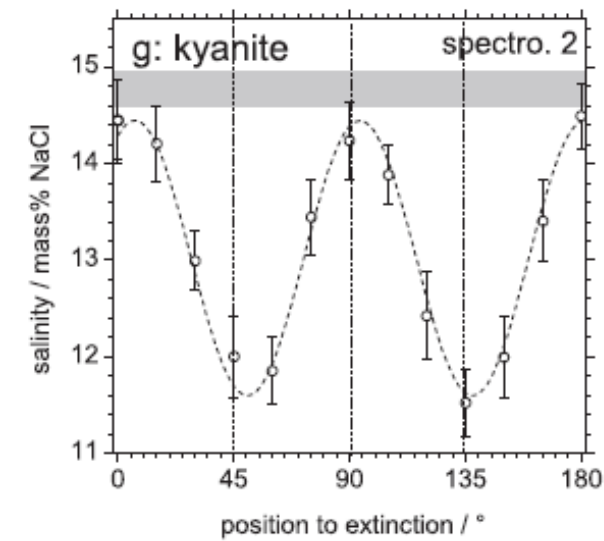
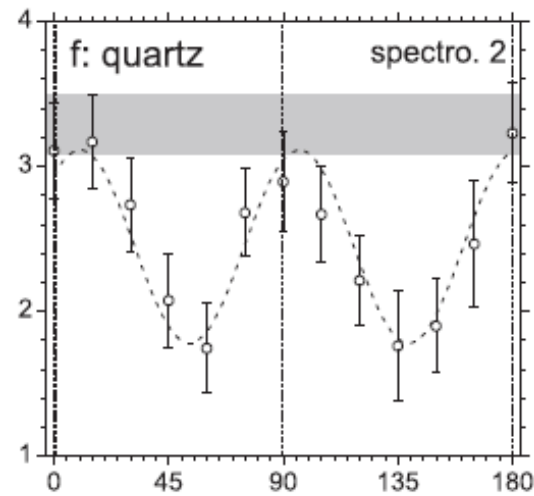
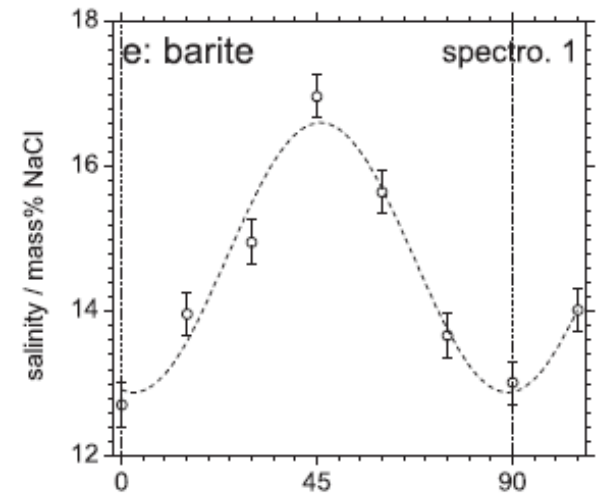

Salinity of fluid inclusions must be measured putting the host crystal at its extinction position.

Salinity meas. in birefringent minerals

Caumon *et al.*, J Raman Spectr 2015

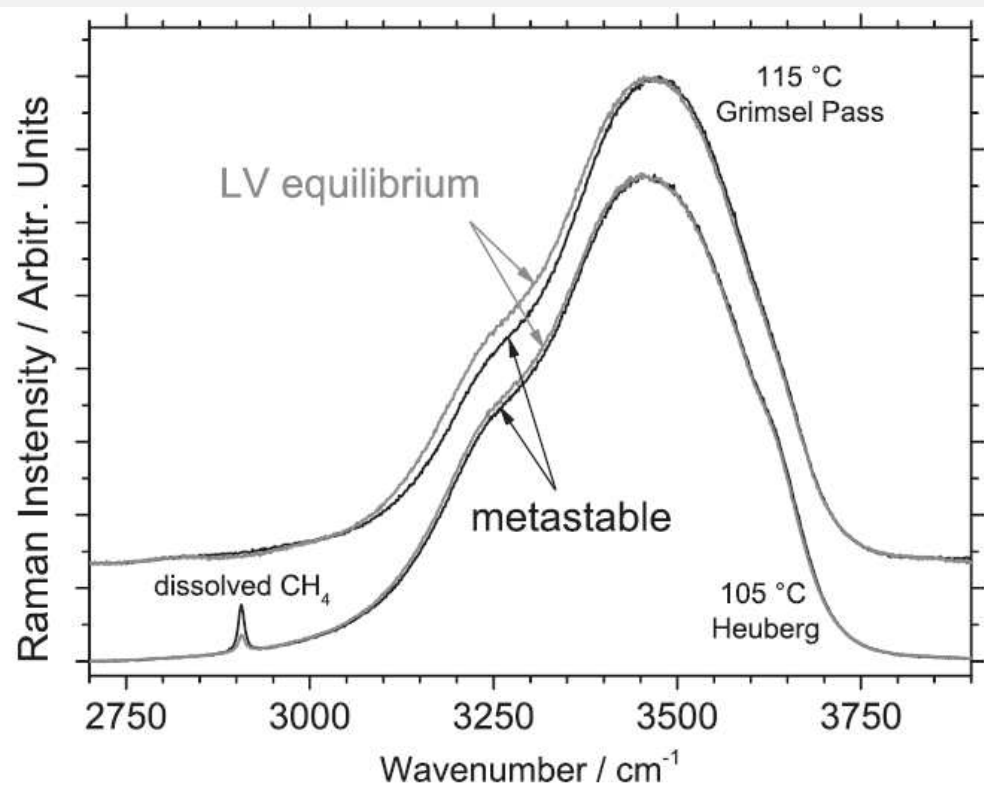

Salinity of metastable inclusions

Tarantola & Caumon, J Raman Spectr 2015

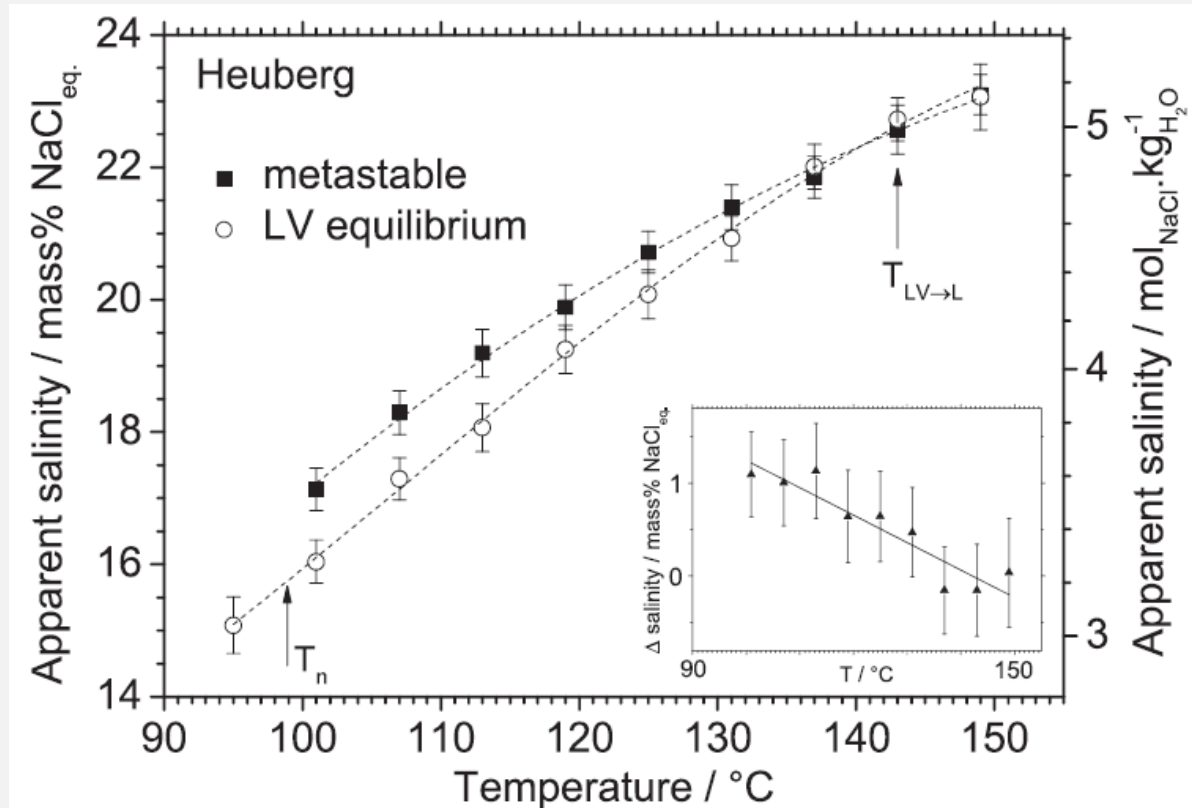

Distorsion of H-bonds in the metastable state.



References

EMU Notes in Mineralogy, Vol. 12 (2012), Chapter 8, 279–320

Raman Spectroscopy of Gases, Water and other Geological Fluids

VALENTIN GARCIA-BAONZA¹, FERNANDO RULL²
and JEAN DUBESSY³

4. Raman Scattering Cross Sections in Gases and Liquids

H. W. Schrötter and H. W. Klöckner

With 14 Figures

Lithos 55 (2001) 139–158

LITHOS

www.elsevier.nl/locate/lithos

Raman microspectrometry of fluid inclusions

Ernst A.J. Burke*

Journal of Geochemical Exploration 112 (2012) 1–20

Contents lists available at SciVerse ScienceDirect

Journal of Geochemical Exploration

journal homepage: www.elsevier.com/locate/jgeoexp



ELSEVIER

Raman spectroscopy for fluid inclusion analysis

Maria Luce Frezzotti^{a,b,*}, Francesca Tecce^b, Alessio Casagli^a



ECROFI 2017

EUROPEAN CURRENT RESEARCH ON FLUID INCLUSIONS

23-29th June 2017
NANCY – FRANCE

FLUID & MELT INCLUSIONS

2017.ecrofi.univ-lorraine.fr

CRPG
Centre de Recherches
Pétrographiques
et Géochimiques

Geo
Ressources